**Electrical requirements for lifts,
escalators and moving walks —**

**Part 1:
Electromagnetic compatibility with
regard to emission**

*Exigences électriques pour ascenseurs, escaliers mécaniques et
trottoirs roulants —*

*Partie 1: Compatibilité électromagnétique en ce qui concerne les
émissions*



Normen-Download-Beuth-VFA-Interliff.e. V.-KdNr.:6363432-ID.Jz_LVJ7IRPYVRSvXeYY1DB7ybsL6G7PeUEgouztP-2023-04-14 08:28:54



COPYRIGHT PROTECTED DOCUMENT

© ISO 2020

All rights reserved. Unless otherwise specified, or required in the context of its implementation, no part of this publication may be reproduced or utilized otherwise in any form or by any means, electronic or mechanical, including photocopying, or posting on the internet or an intranet, without prior written permission. Permission can be requested from either ISO at the address below or ISO's member body in the country of the requester.

ISO copyright office
CP 401 • Ch. de Blandonnet 8
CH-1214 Vernier, Geneva
Phone: +41 22 749 01 11
Fax: +41 22 749 09 47
Email: copyright@iso.org
Website: www.iso.org

Published in Switzerland

Contents

	Page
Foreword	iv
Introduction	v
1 Scope	1
2 Normative references	1
3 Terms and definitions	1
4 Test set-up procedure	5
4.1 General	5
4.2 Radiated and conducted radio-frequency emissions	6
4.3 Voltage fluctuation and flicker	6
4.4 Mains supply harmonics	6
5 Applicability of tests	6
6 Emission limits	7
6.1 Enclosure ports (radiative)	7
6.2 A.C. mains ports (conductive)	7
6.3 Output power ports (conductive)	7
6.4 Impulse noise	7
6.5 Voltage fluctuations	7
6.6 Mains supply current harmonics	8
6.7 Measurement	9
6.7.1 Radiated and conducted radio-frequency emission	9
6.7.2 Mains supply harmonics	10
7 Documentation for the installer of the apparatus/assembly of apparatus	12
Bibliography	13

Foreword

ISO (the International Organization for Standardization) is a worldwide federation of national standards bodies (ISO member bodies). The work of preparing International Standards is normally carried out through ISO technical committees. Each member body interested in a subject for which a technical committee has been established has the right to be represented on that committee. International organizations, governmental and non-governmental, in liaison with ISO, also take part in the work. ISO collaborates closely with the International Electrotechnical Commission (IEC) on all matters of electrotechnical standardization.

The procedures used to develop this document and those intended for its further maintenance are described in the ISO/IEC Directives, Part 1. In particular the different approval criteria needed for the different types of ISO documents should be noted. This document was drafted in accordance with the editorial rules of the ISO/IEC Directives, Part 2 (see www.iso.org/directives).

Attention is drawn to the possibility that some of the elements of this document may be the subject of patent rights. ISO shall not be held responsible for identifying any or all such patent rights. Details of any patent rights identified during the development of the document will be in the Introduction and/or on the ISO list of patent declarations received (see www.iso.org/patents).

Any trade name used in this document is information given for the convenience of users and does not constitute an endorsement.

For an explanation on the voluntary nature of standards, the meaning of ISO specific terms and expressions related to conformity assessment, as well as information about ISO's adherence to the World Trade Organization (WTO) principles in the Technical Barriers to Trade (TBT) see the following URL: www.iso.org/iso/foreword.html.

This document was prepared by Technical Committee ISO/TC 178, *Lifts, escalators and moving walks*.

This first edition of ISO 8102-1 cancels and replaces ISO 22199:2009 which has been technically revised.

Introduction

This document is a type-C standard as stated in ISO 12100.

This document is of relevance, in particular, for the following stakeholder groups representing the market players with regard to machinery safety:

- machine manufacturers (small, medium and large enterprises);
- health and safety bodies (regulators, accident prevention organisations, market surveillance etc.)

Others can be affected by the level of machinery safety achieved with the means of the document by the above-mentioned stakeholder groups:

- machine users/employers (small, medium and large enterprises);
- machine users/employees (e.g. trade unions, organizations for people with special needs);
- service providers, e. g. for maintenance (small, medium and large enterprises);
- consumers (in case of machinery intended for use by consumers).

The above-mentioned stakeholder groups have been given the possibility to participate at the drafting process of this document.

The machinery concerned and the extent to which hazards, hazardous situations or hazardous events are covered are indicated in the Scope of this document.

When requirements of this type-C standard are different from those which are stated in type-A or type-B standards, the requirements of this type-C standard take precedence over the requirements of the other standards for machines that have been designed and built according to the requirements of this type-C standard.

This document is based on EN 12015:2020.

The requirements of this document have been specified so as to ensure a level of electromagnetic emission that causes minimal disturbance to other equipment. The limits given in this document recognize that:

- the product family covers a total range of lifts, escalators and moving walks used in residential buildings, offices, hospitals, hotels, industrial plants, etc.; and
- lifts, escalators and passenger conveyors are deemed to have their own dedicated power supply and be connected with the consent of the supply authority to a low impedance source.

This document is the product family standard for the electromagnetic compatibility of lifts, escalators and moving walks (emission). It takes precedence over all aspects of IEC 61000-6-x. The emission limits given are on the basis that equipment of the product family range is installed both indoors and outdoors in all types of building, involves the switching of heavy currents and high inductive loads and, generally, is connected to a low-voltage system.

The levels, however, do not cover the following cases where:

- a) the probability of an occurrence likely to produce emissions in excess of those which are normally experienced is extremely low, e.g. the emergency stopping of a lift, escalator or passenger conveyor under a fault condition;
- b) highly susceptible apparatus is used in the close proximity of the equipment covered by this document, in which case further measures can be necessary to:
 - 1) reduce the electromagnetic emission to below the levels specified in this document; or

- 2) increase the immunity of the affected apparatus.

The related EMC product family standard for immunity is ISO 8102-2:2017.

Electrical requirements for lifts, escalators and moving walks —

Part 1: Electromagnetic compatibility with regard to emission

1 Scope

This document specifies the emission limits in relation to electromagnetic disturbances and test conditions for lifts, escalators and moving walks, which are intended to be permanently installed in buildings. It is possible, however, that these limits do not provide full protection against disturbances caused to radio and TV reception when such equipment is used within distances given in [Table 1](#).

This document is not applicable for apparatus which are manufactured before the date of its publication

2 Normative references

The following documents are referred to in the text in such a way that some or all of their content constitutes requirements of this document. For dated references, only the edition cited applies. For undated references, the latest edition of the referenced document (including any amendments) applies.

CISPR 11, *Industrial, scientific and medical — Radio-frequency disturbance characteristic — Limits and methods of measurement*

CISPR 14-1:2016+COR1:2016, *Electromagnetic compatibility — Requirements for household appliances, electric tools and similar apparatus — Part 1: Emission*

IEC 61000-3-11, *Electromagnetic compatibility (EMC) — Part 3 11: Limits — Limitation of voltage changes, voltage fluctuations and flicker in public low-voltage supply systems for equipment with rated current up to 75 A and subject to conditional connection*

IEC 61000-3-12, *Electromagnetic compatibility (EMC) — Part 3-12: Limits — Limits for harmonic currents produced by equipment connected to public low-voltage systems with input current > 16 A and ≤ 75 A per phase*

IEC 61000-6-3, *Electromagnetic compatibility (EMC) — Part 6-3: Generic standards — Emission standard for residential, commercial and light-industrial environments*

IEC 61000-6-4, *Electromagnetic compatibility (EMC) — Part 6-4: Generic standards — Emission standard for industrial environments*

3 Terms and definitions

For the purposes of this document, the terms and definitions given in IEC 61000-6-3, IEC 61000-6-4 and the following apply.

ISO and IEC maintain terminological databases for use in standardization at the following addresses:

— ISO Online browsing platform: available at <https://www.iso.org/obp>

— IEC Electropedia: available at <http://www.electropedia.org/>

3.1 apparatus

assembly of components with an intrinsic function as defined by its manufacturer

Note 1 to entry: See [Figure 1](#) and [Figure 2](#).

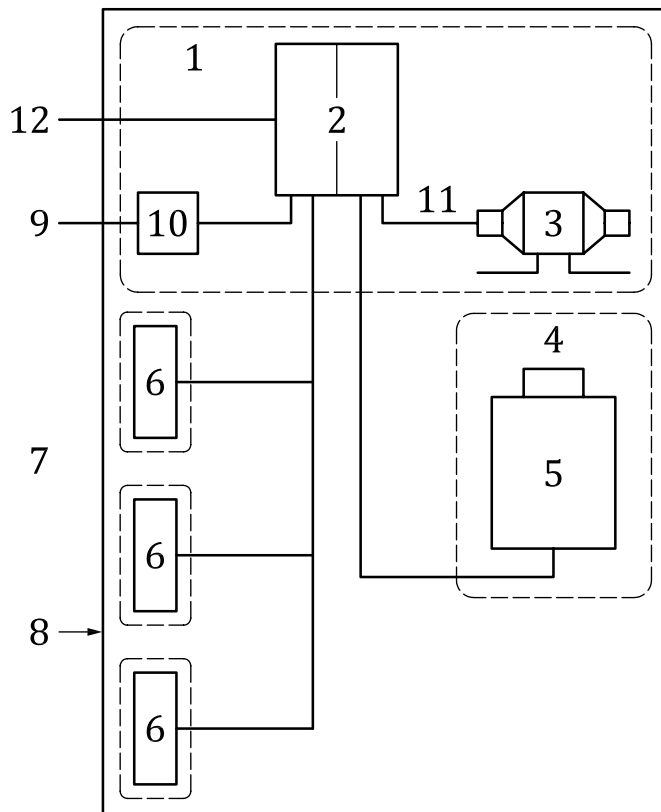

Key

- | | | | |
|---|--|----|---|
|  | assembly of apparatus | 7 | landings |
| 1 | machinery space | 8 | system boundary |
| 2 | main control/control cabinet | 9 | A.C. - and/or D.C. power ports |
| 3 | machine | 10 | main switch |
| 4 | door control | 11 | output power port |
| 5 | lift car | 12 | ports for monitoring and remote alarm systems |
| 6 | apparatus installed at the landing (e.g. push buttons, indicators) | | |

Figure 1 — EMC model example (emission) for lift systems



Key

- assembly of apparatus
- 1 control panels
- 2 machinery space (see 4 to 10)
- 3 system boundary
- 4 machinery space
- 5 main control/control cabinet
- 6 machine
- 7 A.C. and/or D.C. power ports
- 8 main switch
- 9 output power port
- 10 ports for monitoring

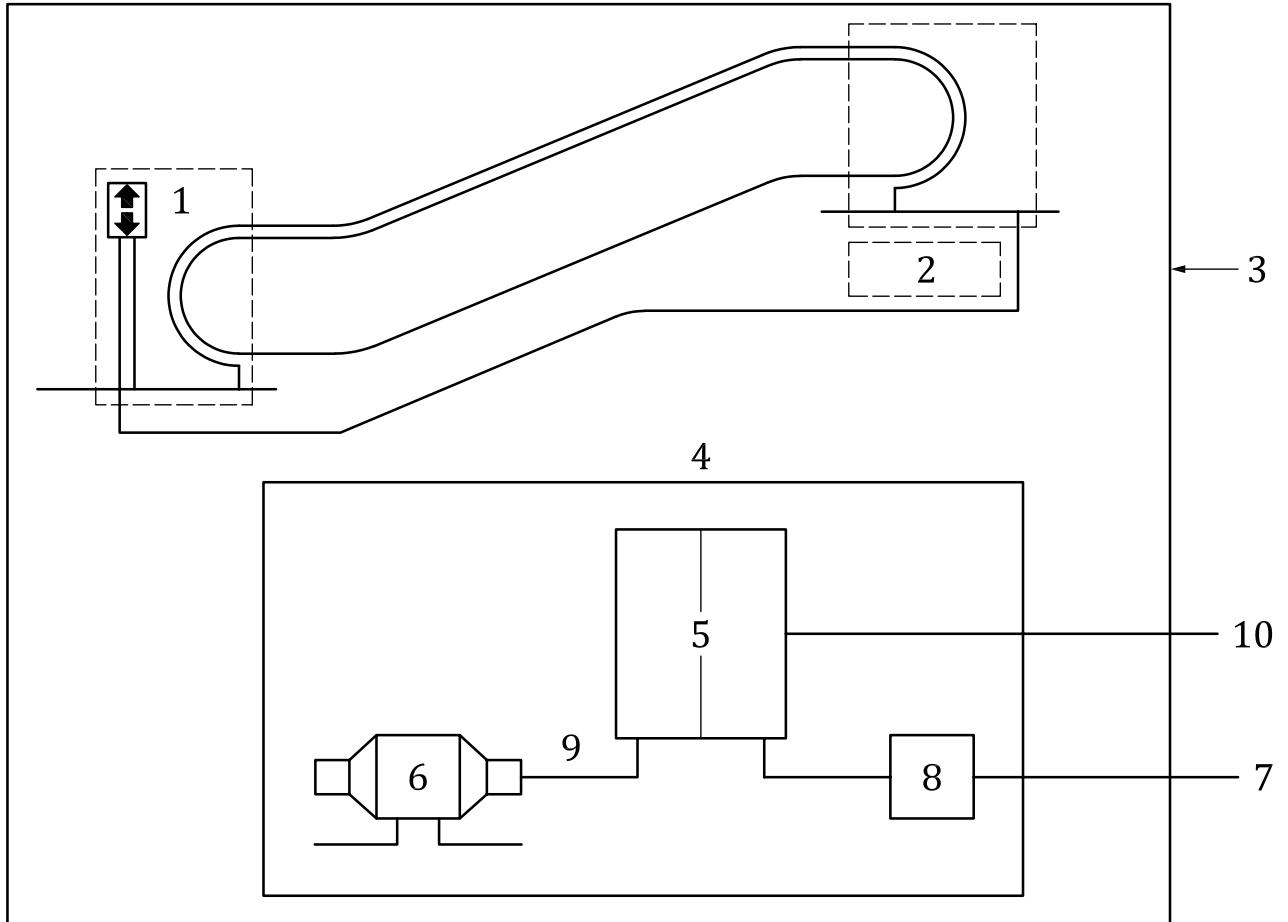
NOTE The machinery space can also be an external room.

Figure 2 — EMC model example (emission) for escalator and moving walk systems

3.2 assembly of apparatus

arrangement of interconnected apparatus, which can be tested together

EXAMPLE See [Figure 1](#) and [Figure 2](#).

3.3 balanced three-phase system (equipment)

three-phase system which is connected to the three line conductors of a three-phase supply and in which the three line or phase currents are designed to be identical in amplitude and wave-shape, each being displaced from the other two by one-third of a fundamental period

[SOURCE: IEC 61000-3-12:2011, 3.7]

3.4 enclosure port

physical boundary of the apparatus/assembly of apparatus through which electromagnetic fields can radiate or impinge

Note 1 to entry: See [Figure 3](#).

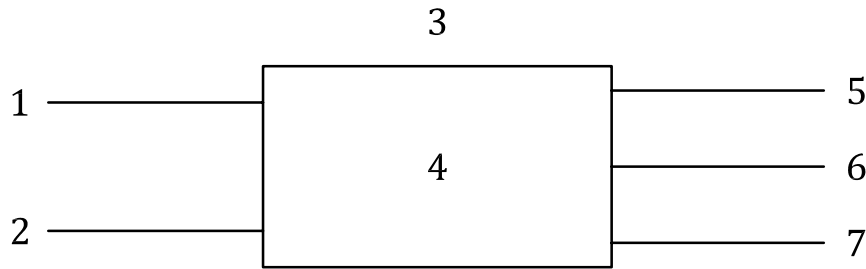

Key

- | | | | |
|---|---------------------------------|---|---------------------|
| 1 | AC power port | 5 | ground port |
| 2 | DC power port | 6 | signal/control port |
| 3 | enclosure port | 7 | machine/motor port |
| 4 | apparatus/assembly of apparatus | | |

Figure 3 — Examples of ports

3.5 hybrid equipment

combination of a balanced three-phase load and one or more loads connected between phase and neutral or between phases

[SOURCE: IEC 61000-3-12:2011, 3.9]

3.6 machine/motor port

A.C./D.C. power supply port of the apparatus/assembly of apparatus containing active electronic circuits connected to the machine/motor

Note 1 to entry: Active electronic circuits comprise electronic components such as transistors, thyristors, digital ICs, microprocessors, and oscillators switching at a variable or fixed rate (switching/clock frequency). An LED display circuit connected to a battery is not an active electronic circuit if the current is limited only by a resistor or by a transistor operating linearly, but it is an active electronic circuit if the current is pulsed.

Note 2 to entry: Controlled speed drive motor supply output is an active electronic circuit. Direct on line or star-delta starting of motors, hoisting and hydraulic pump motors are not active electronic circuits.

Note 3 to entry: Controlled speed drive motor supply output is a machine/motor port. Brake coil is not machine/motor port.

3.7 partial weighted harmonic current PWHC

total r.m.s. value of a selected group of higher order harmonic current components (in this document from order 14 to order 40), weighted with the harmonic order *h*, calculated as:

$$\sqrt{\sum_{h=14}^{40} h \cdot I_h^2}$$

Note 1 to entry: The partial weighted harmonic current is employed in order to ensure that the effects of the higher order harmonic currents on the results are reduced sufficiently and individual limits need not be specified.

[SOURCE: IEC 61000-3-12:2011, 3.2, modified – In the definition, "calculated as" has been added. The abbreviated term has been unitalicized.]

3.8

port

particular interface of the specified apparatus/assembly of apparatus with the external electromagnetic environment

Note 1 to entry: See [Figure 3](#).

3.9

reference current

I_{ref}

value of the r.m.s. input current of the system (equipment) determined according to IEC 61000-3-12, 4.1, and used to establish emission limits

[SOURCE: IEC 61000-3-12:2011, 3.12, modified – The term "system" and reference to "IEC 61000-3-12, 4.1" have been added.]

3.10

root mean square

r.m.s.

effective value of the current

3.11

short circuit ratio

R_{sce}

ratio of the short circuit power of the source to the apparent power of the load(s)

[SOURCE: IEC 61000-3-12:2011, 3.14]

3.12

system (equipment)

lift, escalator or moving walk comprising assembly of apparatus with electrical and electronic equipment and interconnections

Note 1 to entry: See [Figure 1](#) and [Figure 2](#).

Note 2 to entry: Term "system" shall be intended as "equipment" in relation to application of IEC 61000-3-12:2011.

3.13

total harmonic current

THC

total r.m.s. value of the harmonic current components of orders 2 to 40 calculated as:

$$\sqrt{\sum_{h=2}^{40} I_h^2}$$

[SOURCE: IEC 61000-3-12:2011, 3.1, modified – In the definition, "calculated as" has been added. The abbreviated term has been unitalicized.]

4 Test set-up procedure

4.1 General

4.1.1 The measurements shall be made in the operation mode producing the highest emissions consistent with normal applications. An attempt shall be made to maximize the emissions by varying the position of the test sample in the test facility.

4.1.2 It is not always possible to measure emission for every function of the apparatus or assembly of apparatus. In such cases, the most critical period of operation shall be selected under normal operating modes.

4.1.3 If the reference standards do not specify any other conditions, then the tests shall be carried out at a single set of environmental conditions within the manufacturer's specified operating range of temperature, humidity, pressure and supply voltage.

4.1.4 Measurements shall be taken in well-defined and reproducible conditions for each test. The configuration and mode of operation during measurement shall be precisely recorded.

4.2 Radiated and conducted radio-frequency emissions

4.2.1 The tests, test methods, characteristics of the tests and test set-ups shall be as stated in CISPR 11.

4.2.2 Travelling cables or any other cables likely to be more than 5 m long shall be represented by a sample of at least 5 m long connected to the relevant port for the purpose of testing for radiative emission.

4.2.3 If the apparatus has a large number of similar ports or ports with many similar connections, then a sufficient number shall be selected to simulate actual operating conditions and to ensure that all the different types of termination are covered.

4.2.4 Measurement shall be taken at the enclosure ports (radiative), A.C. mains and machine/motor ports (conductive) of the apparatus/assembly of apparatus.

4.3 Voltage fluctuation and flicker

The tests, test methods, characteristics of the tests and test set-ups shall be as stated in IEC 61000-3-11.

4.4 Mains supply harmonics

The calculation or measurement, test methods, characteristics of the tests and test set-ups shall be as stated in IEC 61000-3-12.

The system shall have stabilized into its normal state as defined by the manufacturer before harmonic measurements are taken.

The calculation or measurement shall be done under load condition with a reference current greater than or equal to the reference current as referred to in [6.7.2](#).

5 Applicability of tests

5.1 The application of tests for evaluation of levels of emission depends on the type of apparatus/assembly of apparatus, its configuration, ports, technology and operating conditions.

5.2 It can be determined from consideration of the electrical characteristics and usage of a particular apparatus/assembly of apparatus, that some of the tests are inappropriate and therefore unnecessary. In such a case, the decision and justification not to test shall be recorded.

5.3 Where deviations from the test methods specified in [4.2.1](#) and [4.4](#) are applied, such deviations shall be justified and recorded.

For wired network ports, Class A from CISPR 32 applies.

6 Emission limits

6.1 Enclosure ports (radiative)

The electromagnetic emission levels measured at each enclosure port (radiative) of the apparatus/assembly of apparatus shall not exceed the limits specified in [Table 1](#). These limits are not applicable to in situ measurements.

6.2 A.C. mains ports (conductive)

6.2.1 The electromagnetic emission levels measured at each A.C. mains port (conductive) of the apparatus/assembly of apparatus operating at less than 1 000 V rms shall not exceed the limits specified in [Table 2](#). Different limits apply to emissions resulting from certain rates of impulse noise, as stated in [6.4](#).

6.2.2 The harmonic emission levels measured at each A.C. mains port (conductive) of the three-phase system, operating at less than or equal to 690 V rms shall not exceed the limits specified in [Tables 4 to 7](#).

The harmonic emission levels measured at each A.C. mains port (conductive) of the single-phase system operating at less than or equal to 240 V rms shall not exceed the limits specified in [Table 7](#).

6.3 Output power ports (conductive)

The electromagnetic emission levels at each machine/motor port (conductive) of the apparatus/assembly of apparatus shall not exceed the limits specified in [Table 3](#). If shielded connectors and shielded cables, in accordance with the apparatus/assembly of the apparatus manufacturer's specifications, are used for machine/motor ports, or the cables are less than or equal to 2 m long, measurements at those ports are not necessary.

6.4 Impulse noise

Electromagnetic emission levels resulting from impulse noise (clicks), measured as for [6.2.1](#), shall not exceed the limits specified in [Table 2](#) if the clicks occur more frequently than 30 times per minute. Electromagnetic emission levels resulting from clicks which occur between 0,2 times and 30 times per minute shall not exceed the limits specified in [Table 2](#) raised by a value, in dB (μV), of:

$$20\log_{10} = \frac{30}{N}$$

where N is the number of clicks per minute.

These limits do not apply for the exceptions given in CISPR 14-1:2016+COR1:2016, 5.4.3.

6.5 Voltage fluctuations

The requirements of IEC 61000-3-11 apply to a system.

Voltage fluctuations are dependent on the impedance of the mains supply for an individual system and the characteristics of the apparatus/assembly of apparatus. The manufacturer shall document the maximum impedance of the electricity mains supply for the system.

Apparatus/assembly of apparatus using controlled speed drives are known not to be a cause of voltage flicker disturbance. However, direct on line or star-delta starting of escalator motors, hoisting and hydraulic pump motors and repetitive direct switching of highly inductive loads (e.g. transformer) should be treated with caution.

6.6 Mains supply current harmonics

6.6.1 Lifts, escalators and moving walks are considered as professional equipment as defined by IEC 61000-3-2. Therefore, the requirements of IEC 61000-3-12 shall be applied as well to a system (equipment) less than 16 A per phase.

Harmonic currents of single-phase apparatus/assembly of apparatus shall be included in the assessment of harmonic current of system (equipment).

The harmonic emission levels measured at each A.C. mains port (conductive) of the three-phase system, operating at less than or equal to 690 V r.m.s. shall not exceed the limits specified in [Tables 4 to 7](#).

The harmonic emission levels measured at each A.C. mains port (conductive) of the single-phase system operating at less than or equal to 240 V r.m.s. shall not exceed the limits specified in [Table 7](#).

6.6.2 The limits of [Tables 4 to 6](#) apply to a balanced three-phase system (equipment) or a hybrid system (equipment) in one of the following circumstances:

- a) hybrid equipment having a maximum third harmonic current of less than 5 % of the reference current; or
- b) there is provision in the construction of hybrid equipment to separate the balanced three-phase and the single-phase or interphase loads for the measurement of supply currents, and when the current is being measured, the part of the equipment being measured draws the same current as under normal operating conditions. In that case, the relevant limits shall be applied separately to the single-phase or interphase part and to the balanced three-phase part. [Table 4](#), [Table 5](#) or [Table 6](#) applies to the current of the balanced three-phase part, even if the rated current of the balanced three-phase part is less than or equal to 16 A per phase. [Table 7](#) applies to the current of the single-phase or interphase part but, if the rated current of the single-phase or interphase part is less than or equal to 16 A, the relevant limits of IEC 61000-3-2 to the single-phase or interphase part can be applied instead of the limits stated in [Table 7](#).

6.6.3 The limits of [Table 5](#) apply to a balanced three-phase system (equipment) if any one of these conditions is met:

- a) the fifth and seventh harmonic currents are each less than 5 % of the reference current during the whole test observation period;

NOTE 1 This condition is normally fulfilled by a system (equipment) where the largest electrical load is a three-phase 12-pulse equipment.

- b) the design of the piece of equipment is such that the phase angle of the fifth harmonic current has no preferential value over time and can take any value in the whole interval $[0^\circ, 360^\circ]$;

NOTE 2 This condition is normally fulfilled by a system (equipment) where the largest electrical load is a three-phase converter with fully controlled thyristor bridges.

- c) the phase angle of the fifth harmonic current related to the fundamental phase-to-neutral voltage (see IEC 61000-3-12:2011, 3.16) is in the range of 90° to 150° during the whole test observation period;

NOTE 3 This condition is normally fulfilled by a system (equipment) where the largest electrical load has a three-phase uncontrolled rectifier bridge and capacitive filter, including a 3 % A.C. or 4 % D.C. reactor.

6.6.4 The limits of [Table 6](#) apply to a balanced three-phase system (equipment) if any one of these conditions is met:

- a) the fifth and seventh harmonic currents are each less than 3 % of the reference current during the whole test observation period;

- b) the design of the piece of equipment is such that the phase angle of the fifth harmonic current has no preferential value over time and can take any value in the whole interval [0°, 360°];
- c) the phase angle of the fifth harmonic current related to the fundamental phase-to-neutral voltage (see IEC 61000-3-12:2011, 3.16) is in the range of 150° to 210° during the whole test observation period;

NOTE This condition is normally fulfilled by a system (equipment) where the largest electrical load is a 6-pulse converter with a small D.C. link capacitance, operating as a load.

6.6.5 The limits of [Table 7](#) apply to system (equipment) other than balanced three-phase system (equipment) or to a hybrid system (equipment) with third harmonic order greater than or equal to 5 % of the reference current.

The application of [Tables 4](#) to [7](#) follows the flow chart in IEC 61000-3-12:2011, 5.2, with tables corresponding as follows:

- a) IEC 61000-3-12:2011, Table 2, corresponds to [Table 7](#);
- b) IEC 61000-3-12:2011, Table 3, corresponds to [Table 4](#);
- c) IEC 61000-3-12:2011, Table 4, corresponds to [Table 5](#).
- d) IEC 61000-3-12:2011, Table 5, corresponds to [Table 6](#).

6.7 Measurement

6.7.1 Radiated and conducted radio-frequency emission

To determine conformity to the requirements of [6.1](#) and [6.2.1](#), emission levels shall be measured by the methods specified in CISPR 11 and under the conditions specified in [Clause 4](#).

To determine conformity to the requirements of [6.3](#), the measurement method as defined in CISPR 14-1 for load terminals shall be used.

Table 1 — Emission limits for enclosure (radiative) ports

Frequency range, <i>F</i> MHz	Limits for measurements on a test site at 10 m distance ^a dB(μV/m)
$30 \leq F < 230$	40 quasi peak
$230 \leq F \leq 1000$	47 quasi peak

^a These limits are based on those specified in IEC 61000-6-4. Measurements made at a distance of less than 10 m shall be made in accordance with CISPR 11. Measurements shall not be taken at a distance of less than 3 m.

Table 2 — Emission limits for A.C. mains (conductive) ports

Frequency range, <i>F</i> MHz	Limits dB(μV)		
	Measurement for equipment rated current ^a		
	<25 A	25-100 A	>100 A ^b
$0,15 \leq F < 0,5$	79 quasi peak 66 average	100 quasi peak 90 average	130 quasi peak 120 average

^a The current for which the apparatus has been designed.
^b This requires a dedicated power supply from a specific transformer.
^c Decreasing with logarithm of frequency.

Table 2 (continued)

Frequency range, <i>F</i> MHz	Limits dB(μV)		
	Measurement for equipment rated current ^a		
	<25 A	25-100 A	>100 A ^b
0,5 ≤ <i>F</i> < 5,0	73 quasi peak 60 average	86 quasi peak 76 average	125 quasi peak 115 average
5,0 ≤ <i>F</i> < 30	73 quasi peak 60 average	90 to 70 ^c quasi peak 80 to 60 ^c average	115 quasi peak 105 average

^a The current for which the apparatus has been designed.
^b This requires a dedicated power supply from a specific transformer.
^c Decreasing with logarithm of frequency.

Table 3 — Emission limits for machine/motor port

Frequency range, <i>F</i> MHz	Limits dB(μV)
0,15 ≤ <i>F</i> < 0,5	80 quasi peak 70 average
0,5 ≤ <i>F</i> < 5,0	74 quasi peak 64 average
5,0 ≤ <i>F</i> < 30	74 quasi peak 64 average

6.7.2 Mains supply harmonics

The ratios I_h/I_{ref} used for comparison with the limits given in [Tables 4 to 7](#) shall be based on at least the reference current of the system.

Individual harmonics below 1 % of the reference current are disregarded.

The limits given apply to 230 V/400 V, 50 Hz systems.

Table 4 — Harmonic current emission limits for balanced three-phase system (equipment) and hybrid system (equipment) under the circumstances of [6.6.2](#)

Environmental phenomena	Test set-up	Limits ^a		
		%		
Harmonic emission	IEC 61000-3-12	Admissible individual harmonic current	I_5/I_{ref}	31
			I_7/I_{ref}	20
			I_{11}/I_{ref}	12
		I_h/I_{ref}	I_{13}/I_{ref}	7
			THC	37
			PWHC	38

The relative value of even harmonics up to order 12 shall not exceed $16/h$ [%]. Even harmonics above order 12 are taken into account in THC and PWHC in the same way as odd order harmonics.

^a The given limits are based on IEC 61000-3-12 for $R_{sce} = 250$.

Table 5 — Harmonic current emission limits for balanced three-phase system (equipment) under specified conditions (6.6.3) and hybrid system (equipment) under the circumstances of 6.6.2

Environmental phenomena	Test set-up	Limits ^a		
		%		
Harmonic emission	IEC 61000-3-12	Admissible individual harmonic current	I_5/I_{ref}	40
			I_7/I_{ref}	25
			I_{11}/I_{ref}	15
			I_{13}/I_{ref}	10
		Admissible harmonic parameters ^a	THC	48
			PWHC	46
The relative value of even harmonics up to order 12 shall not exceed $16/h$ [%]. Even harmonics above order 12 are taken into account in THC and PWHC in the same way as odd order harmonics.				
^a The given limits are based on IEC 61000-3-12 for $R_{sce} \geq 120$.				

Table 6 — Harmonic current emission limits for balanced three-phase system (equipment) under specified conditions (6.6.4) and hybrid system (equipment) under the circumstances of 6.6.2

Environmental phenomena	Test set-up	Limits ^a		
		%		
Harmonic emission	IEC 61000-3-12	Admissible individual harmonic current	I_5/I_{ref}	25
			I_7/I_{ref}	17,3
			I_{11}/I_{ref}	12,1
			I_{13}/I_{ref}	10,7
			I_{17}/I_{ref}	8,4
			I_{19}/I_{ref}	7,8
			I_{23}/I_{ref}	6,8
			I_{25}/I_{ref}	6,5
			I_{29}/I_{ref}	5,4
			I_{31}/I_{ref}	5,2
			I_{35}/I_{ref}	4,9
			I_{37}/I_{ref}	4,7
		Admissible harmonic parameters ^a	THC	35
			PWHC	70
The relative value of even harmonics up to order 12 shall not exceed $16/h$ [%]. The relative values of all harmonics from I_{14} to I_{40} not listed above shall not exceed 3 % of I_{ref} .				
^a The given limits are based on IEC 61000-3-12 for $R_{sce} \geq 250$.				

Normen-Download-Beuth-VFA-Interliff.e.V.-KdNr.6363432-ID.jz_LV7IRPVYRSvXeYY1DB7ybsL6G7PeUEgouztP-2023-04-14 08:28:54

Table 7 — Harmonic current emission limits for single-phase system (equipment) and hybrid system (equipment) with third harmonic order ≥ 5 % of reference current

Environmental phenomena	Test set-up	Limits ^a		
		%		
Harmonic emission	IEC 61000-3-12	Admissible individual harmonic current I_h/I_{ref}	I_3/I_{ref}	35
			I_5/I_{ref}	20
			I_7/I_{ref}	13
			I_9/I_{ref}	9
			I_{11}/I_{ref}	8
			I_{13}/I_{ref}	6
		Admissible harmonic parameters ^a	THC	40
			PWHC	40
		The relative value of even harmonics up to order 12 shall not exceed $16/h$ [%]. Even harmonics above order 12 are taken into account in THC and PWHC in the same way as odd order harmonics.		
^a The given limits are based on IEC 61000-3-12 for $R_{sce} = 250$.				

7 Documentation for the installer of the apparatus/assembly of apparatus

The installer shall be provided with documentary information and instructions for installation and use so that compliance with this document is maintained.

This shall include where applicable:

- a) instructions for assembly and physical arrangement with other apparatus;
- b) instructions and precautions for interconnection to other apparatus;
- c) specifications of interconnection cables and devices, especially about the application of shielded cables;
- d) instructions for commissioning and testing;
- e) guidance on avoiding incorrect actions and assembly of apparatus which are known to cause non-compliance with this document.

Normen-Download-Beuth-VFA-Interliff.e. V.-KdNr. 6363432-1D.Jz_LV7IRPVYRSvXeYY1DB7y5L6G7PeUEgouztP-2023-04-14 08:28:54

Bibliography

- [1] ISO 8102-2, *Electrical requirements for lifts, escalators and moving walks — Part 2: Electromagnetic compatibility with regard to immunity*
- [2] ISO 12100, *Safety of machinery — General principles for design — Risk assessment and risk reduction*
- [3] IEC 61000-3-2, *Electromagnetic compatibility (EMC) — Part 3-2: Limits — Limits for harmonic current emissions (equipment input current ≤ 16 A per phase)*
- [4] CISPR 32, *Electromagnetic compatibility of multimedia equipment — Emission requirements*
- [5] EN 12015:2020, *Electromagnetic compatibility - Product family standard for lifts, escalators and moving walks - Emission*

Normen-Download-Beuth-VFA-Interliff e. V.-KdNr. 6363432-ID.Jz_LVJ7IRPVYRSvXeYY1DE7ybsL6G7PeUEgouztP-2023-04-14 08:28:54

ICS 91.140.90

Price based on 13 pages

© ISO 2020 – All rights reserved