

DRAFT INTERNATIONAL STANDARD

ISO/DIS 8100-30

ISO/TC 178

Secretariat: AFNOR

Voting begins on:
2017-11-30

Voting terminates on:
2018-02-22

Lifts for the transport of persons and goods —

Part 30: Class I, II, III and IV lifts installation

*Ascenseurs pour le transport des personnes et des charges —
Partie 30: Installation d'ascenseurs des classes I, II, III et IV*

ICS: 91.140.90

THIS DOCUMENT IS A DRAFT CIRCULATED FOR COMMENT AND APPROVAL. IT IS THEREFORE SUBJECT TO CHANGE AND MAY NOT BE REFERRED TO AS AN INTERNATIONAL STANDARD UNTIL PUBLISHED AS SUCH.

IN ADDITION TO THEIR EVALUATION AS BEING ACCEPTABLE FOR INDUSTRIAL, TECHNOLOGICAL, COMMERCIAL AND USER PURPOSES, DRAFT INTERNATIONAL STANDARDS MAY ON OCCASION HAVE TO BE CONSIDERED IN THE LIGHT OF THEIR POTENTIAL TO BECOME STANDARDS TO WHICH REFERENCE MAY BE MADE IN NATIONAL REGULATIONS.

RECIPIENTS OF THIS DRAFT ARE INVITED TO SUBMIT, WITH THEIR COMMENTS, NOTIFICATION OF ANY RELEVANT PATENT RIGHTS OF WHICH THEY ARE AWARE AND TO PROVIDE SUPPORTING DOCUMENTATION.

This document is circulated as received from the committee secretariat.



Reference number
ISO/DIS 8100-30:2017(E)

© ISO 2017



COPYRIGHT PROTECTED DOCUMENT

© ISO 2017, Published in Switzerland

All rights reserved. Unless otherwise specified, no part of this publication may be reproduced or utilized otherwise in any form or by any means, electronic or mechanical, including photocopying, or posting on the internet or an intranet, without prior written permission. Permission can be requested from either ISO at the address below or ISO's member body in the country of the requester.

ISO copyright office
Ch. de Blandonnet 8 • CP 401
CH-1214 Vernier, Geneva, Switzerland
Tel. +41 22 749 01 11
Fax +41 22 749 09 47
copyright@iso.org
www.iso.org

Contents

Page

Foreword.....	v
Introduction	vi
1 Scope	1
2 Terms and definitions	1
2.1 General.....	1
2.2 Lift classes	2
2.3 Dimensions.....	2
2.4 Other characteristics.....	5
3 Lift characteristics	5
3.1 Renard series	5
3.2 Rated loads.....	6
3.3 Rated speeds.....	6
3.4 Selection of class of lift.....	6
4 Dimensions.....	6
4.1 Inner dimensions of cars	6
4.1.1 Accessibility.....	6
4.1.2 Class I lifts	7
4.1.3 Class II lifts	7
4.1.4 Class III lifts	7
4.1.5 Class VI lifts.....	7
4.2 Inner dimensions of well.....	8
4.2.1 Plan dimensions	8
4.2.2 Individual lifts.....	11
4.2.3 Multiple lifts situated side by side	11
4.2.4 Distance between landings.....	11
4.3 Dimensions of landings	11
4.3.1 General.....	11
4.3.2 Class I lifts particularly intended for residential buildings	11
4.3.3 Class I (other than those particularly intended for residential buildings), II, III and VI lifts	12
4.4 Dimensions of electric lifts	12
4.4.1 Individual lifts.....	12
4.4.2 Multiple lifts	12
4.5 Dimensions of hydraulic lifts.....	13
4.5.1 Individual lifts.....	14
4.5.2 Duplex group lifts	14
4.6 Arrangement of machine room (where applicable).....	14
4.6.1 Individual or common arrangement.....	14
4.6.2 Arrangement for individual lifts and multiple lifts side by side with common machine room	17
4.6.3 Arrangement for lifts face to face with a common machine room (for electric lifts only)	17
Bibliography	30

Foreword

ISO (the International Organization for Standardization) is a worldwide federation of national standards bodies (ISO member bodies). The work of preparing International Standards is normally carried out through ISO technical committees. Each member body interested in a subject for which a technical committee has been established has the right to be represented on that committee. International organizations, governmental and non-governmental, in liaison with ISO, also take part in the work. ISO collaborates closely with the International Electrotechnical Commission (IEC) on all matters of electrotechnical standardization.

International Standards are drafted in accordance with the rules given in the ISO/IEC Directives, Part 2.

The main task of technical committees is to prepare International Standards. Draft International Standards adopted by the technical committees are circulated to the member bodies for voting. Publication as an International Standard requires approval by at least 75 % of the member bodies casting a vote.

Attention is drawn to the possibility that some of the elements of this document may be the subject of patent rights. ISO shall not be held responsible for identifying any or all such patent rights.

ISO 8100-30 was prepared by Technical Committee ISO/TC 178, *Lifts, escalators and moving walks*.

Due to the decision of ISO TC 178 to renumber all standards of this TC for more consistency, former ISO 4190-1 becomes now ISO 8100-30.

This fifth edition cancels and replaces the fourth edition (ISO 4190-1:2010). This edition reflects the requirements of the global marketplace and includes

- a) reference to machine room-less lifts and the inclusion of additional dimensions to cope with common machine room-less lift configurations;
- b) inclusion of some new and revised car sizes to provide for access by persons including persons with disability.

NOTE 1 In certain instances, harmonization is not possible and these sizes are shown in Figures 10, 11 a), 11 b), and 11 c).

NOTE 2 National regulations can demand greater dimensions in some instances.

Introduction

This part of ISO 8100 reflects the requirements of the global marketplace and includes:

- the special needs, access and full manoeuvrability of persons including persons with physical disabilities;
- appropriate use of stretchers, beds and ancillary medical equipment in hospitals and nursing homes;
- a range of intensive-use lifts¹ typically used for high-rise buildings for rated speeds of 2,5 m/s to 6,0 m/s;
- rated speeds mainly based upon the Renard series for speeds of up to 2,5 m/s;
- improved utilization of building space by reducing well (hoistway) sizes where practicable.

¹ Hereinafter, the term “lift” is used instead of the term “elevator”.

Lifts for the transport of persons and goods : Part 30 : Class I, II, III and IV lifts installations

1 Scope

This part of ISO 8100 specifies the necessary dimensions to permit the installation of passenger lifts of class I, II, III and VI.

The dimensions given reflect the requirements for the apparatus. This part of ISO 8100 is applicable to all new lift installations, irrespective of drive systems, including a car with one entrance, to be installed in a new building. However, for arrangements with counterweight at the side, a through-entrance configuration is possible. Where relevant, this part of ISO 8100 is also applicable to an installation in an existing building.

This part of ISO 8100 is not applicable to lifts of rated speed greater than 6,0 m/s.

NOTE It is the responsibility of the user to consult the manufacturer for such installations.

2 Terms and definitions

For the purposes of this part of ISO 8100, the following terms and definitions apply.

2.1 General

2.1.1

car

part of the lift which carries the passenger and/or other loads

2.1.2

head room

part of the well situated above the highest landing served by the car

2.1.3

landing

area providing access to the car at each level of use

2.1.4

machine room

room in which the machine or machines and/or the associated equipment are placed

2.1.5

machine room-less lift

lift whose machinery spaces, e.g. control cabinet(s) and drive system, lift machine, main switch(es), and means for emergency operations, are inside the well or on the landing(s)

2.1.6

lift GB elevator US

permanent lifting appliance serving defined landing levels, comprising a car, the dimensions and means of construction of which, clearly permit the access of passengers

2.1.7

pit

part of the well situated below the lowest landing served by the car

2.1.8

through entrance car

car with doors at the front and rear which may or may not be able to open at the same time

2.1.9

well hoistway

space in which the car, the counterweight(s) and hydraulic jack(s) move

NOTE This space is usually bounded by the bottom of the pit, the walls and the ceiling of the well.

2.2 Lift classes

2.2.1

class I

lift designed for the transport of persons

2.2.2

class II

lift designed mainly for the transport of persons, but in which goods may be carried

NOTE This differs from a class I, III and VI lift, essentially, by the inner fittings of the car and by the strength of the car floor etc.

2.2.3

class III

lift designed for health-care purposes, including hospitals and nursing homes

2.2.4

class IV

lift designed mainly for the transport of goods (freight) which are generally accompanied by persons

2.2.5

class V service lift GB

dumbwaiter US

2.2.6

class VI

lift especially designed to suit buildings with intensive traffic, i.e. lifts with speeds of 2,5 m/s and above

2.3 Dimensions

See Figure 1.

2.3.1

car width

***b*₁**

horizontal distance between the inner surface of the car walls measured parallel to the front entrance side

NOTE This dimension is measured as indicated in Figure 1, 1 m above the floor. In certain regions, e.g. Asia-Pacific and North American regions, the car width, *b*₁, is measured between the finished panels, whereas in Europe, the car width is measured excluding decorative or protective panels.

2.3.2

car depth

***d*₁**

horizontal distance between the internal walls of the car, measured perpendicular to the front entrance side

NOTE This dimension is measured as indicated in Figure 1, 1 m above the floor. In certain regions, e.g. Asia-Pacific and North American regions, the car depth, *d*₁, is measured between the finished panels, whereas in Europe, the car depth is measured excluding decorative or protective panels.

2.3.3

car height

h4
vertical inner distance between the entrance threshold and the constructional roof of the car.

NOTE 1 Light fittings and false ceilings should be accommodated within this dimension (see Figure 1).

NOTE 2 In certain regions, e.g. Asia-Pacific and North American regions, the car height, *h4*, is measured between the floor and the underside of the false ceiling, whereas in Europe, the car height is measured to the underside of the structural roof.

2.3.4

entrance width into car

b2
clear width of the entrance, measured when the landing and car doors are fully open

2.3.5

entrance height

h3
clear height of the entrance, measured when the landing doors and car doors are fully open

2.3.6

well width GB hoistway width US *b3*

horizontal distance between the inner surface of the well walls, measured parallel to the car width

2.3.7

well depth GB hoistway depth US *d2*

horizontal dimension between the inner surface of the well walls, perpendicular to the width

2.3.8

pit depth

d3
vertical distance between the finished floor of the lowest landing served and the bottom of the well

2.3.9

headroom height

h1
vertical distance between the finished floor of the highest landing served and the ceiling of the well (not including any pulley over line of car)

2.3.10

machine room width

b4
horizontal dimension between the inner surface of the walls, measured parallel to the car width

See Figure 3.

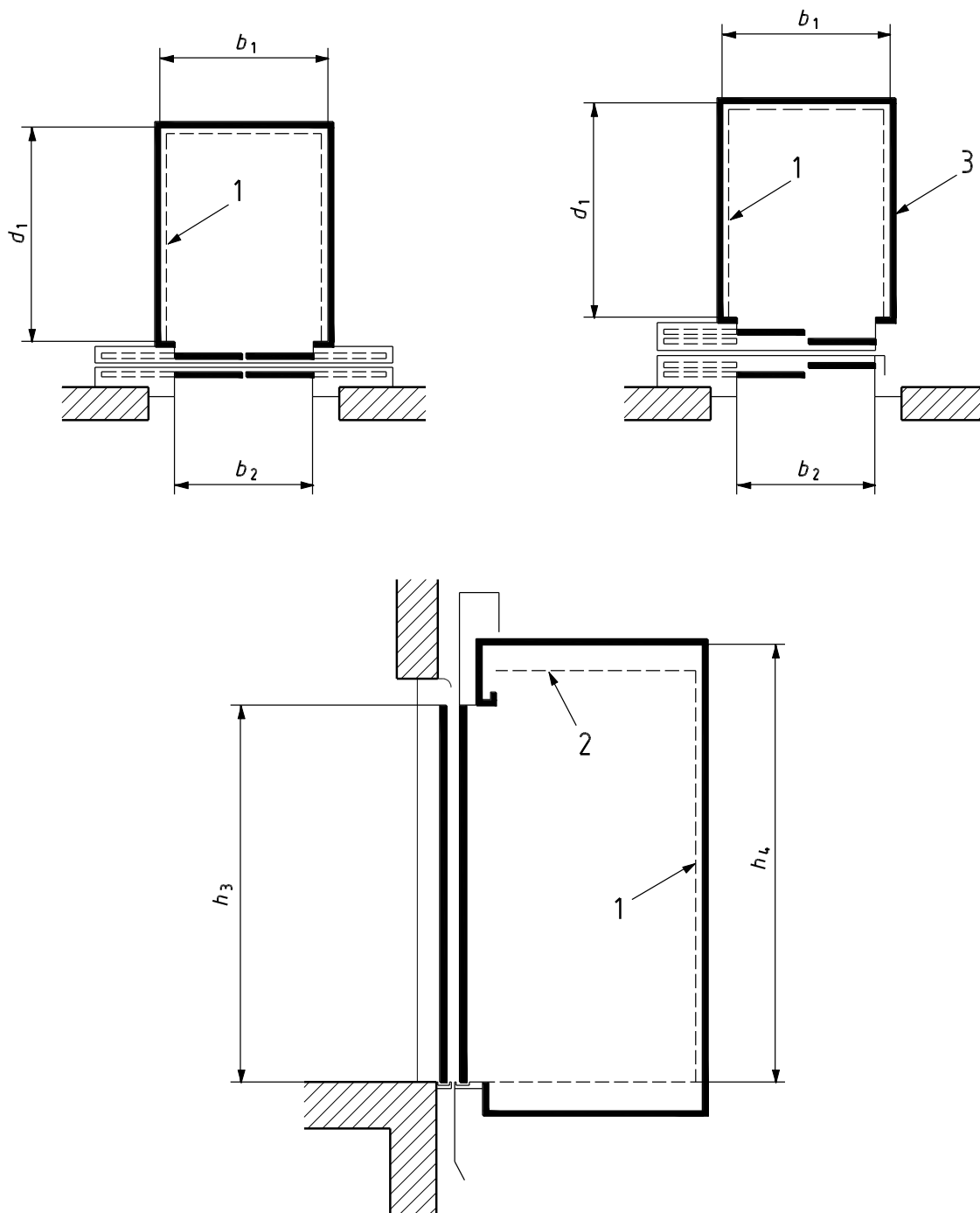

Key

- 1 decorative panels
- 2 false ceiling
- 3 car wall
- b_1 car width
- b_2 entrance width
- d_1 car depth
- h_3 entrance height
- h_4 car height

Figure 1 — Car and entrance dimensions

2.3.11

machine room depth

d4

horizontal dimension between the inner surface of the walls, perpendicular to the width

2.3.12

machine room height

h2

smallest vertical distance between the finished floor and the room ceiling, satisfying both the requirements of the national building regulations and lift equipment

2.4 Other characteristics

2.4.1

rated speed

v

speed for which the lift has been built and at which it is designed to operate

2.4.2

rated load

load for which the lift has been built and under which it is designed to operate

2.4.3

group collective lift GB

group collective elevator US

group of electrically interconnected lifts for which landing controls are common

3 Lift characteristics

3.1 Renard series

The dimensions of the car are related to the loads which have been selected to be close to the Renard R10 series of preferred numbers.

The dimensions of the pit, headroom and machine room have been determined in relation to the speeds which, up to 2,5 m/s, are based on the R5 series of preferred numbers.

NOTE The Renard series is a series of preferred numbers adopted at the international level in 1946 (Budapest International Congress).

The Renard series is a geometrical progression and has a multiplier selected on exponents of 10. For lifts, the multipliers are:

— car load: $R10 = \sqrt[10]{10} = 1,258\ 9$

— car speed: $R5 = \sqrt[5]{10} = 1,584\ 9$

The results are approximate, which give:

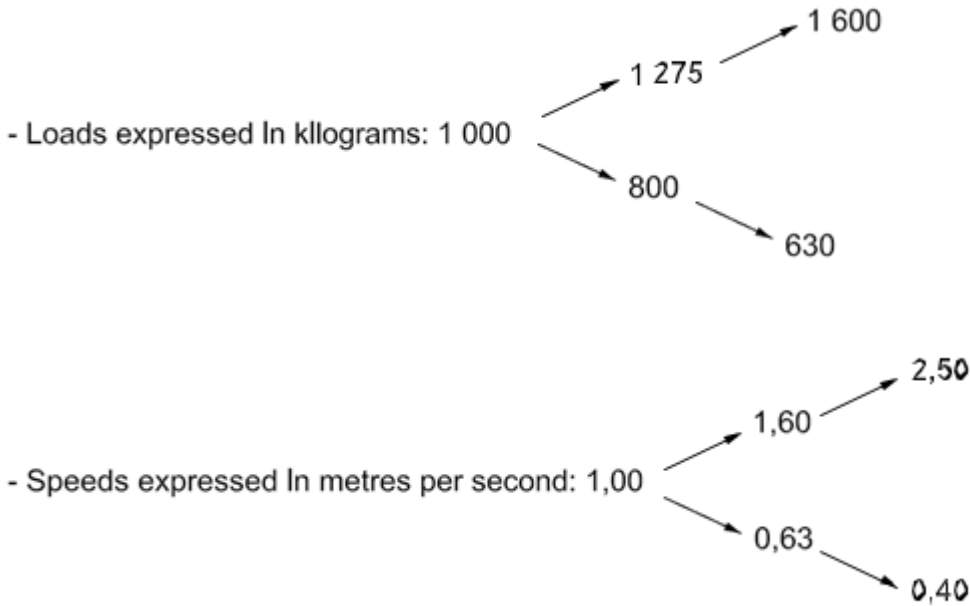

3.2 Rated loads

These shall be, in kilograms:

- 450 - 630 - 800 – 1 000 - 1 275 – 1 350 - 1 600 - 1 800 - 2 000 - 2 500

NOTE 1 350 kg (3 000 lb) and 1 800 kg (4 000 lb) are not Renard numbers, but are popular sizes in the Asia-Pacific and North American regions.

3.3 Rated speeds

These shall be, in metres per second:

- 0,40 - 0,63 - 0,75 - 1,00 - 1,50 - 1,60 – 1,75 - 2,00 - 2,50 - 3,00 - 3,50 - 4,00 - 5,00 - 6,00

NOTE 0,75, 1,50, 1,75, 2,00, 3,00 and 5,00, are not Renard numbers, but are popular speeds in the Asia-Pacific and North American regions.

Speeds from 0,63 m/s to 6,00 m/s apply to electric lifts. Speeds from 0,40 m/s to 1,00 m/s apply to hydraulic lifts.

3.4 Selection of class of lift

Any type of building may be equipped with lifts of different classes. The lifts are grouped in Figures 5 to 11 a), 11 b) and 11 c).

4 Dimensions

4.1 Inner dimensions of cars

4.1.1 Accessibility

It is recommended that in multi-storey buildings there be at least one lift accessible to transport persons in wheelchairs.

ISO/DIS 8100-30:2017(E)

This lift shall meet all conditions required for this application, and shall be indicated by the sign:



Accessible for a wheelchair user.

NOTE 1 ISO 4190-5 provides requirements for control devices, signals and additional fittings for such lifts.

NOTE 2 The accessibility requirements are subject to national regulations. In some regions, it is more usual for all lifts in a group to be accessible to persons with impaired mobility.

4.1.2 Class I lifts

Class I lifts are passenger lifts (see Figures 5, 6 and 7 and Table 2). Lifts for local markets are shown in Figures 10, 11 a), 11 b) and 11 c).

4.1.2.1 The following lifts for residential buildings are shown in Table 2:

- a) cars for 450 kg rated load lifts allow only the transport of persons or a wheelchair, but without an accompanying person;
- b) cars for 630 kg rated load lifts allow, in addition, the transport of a person in a wheelchair with an accompanying person (but do not allow full manoeuvrability, i.e. turning full-circle);
- c) cars for 1 000 kg rated load lifts allow, depending on car size, the transport of stretchers with removable handles and of coffins and furniture or the transport of a person in a wheelchair allowing full manoeuvrability i.e. turning circle.

4.1.2.2 General-purpose lifts shall be used mainly in low- and medium-rise buildings, typically up to 15 floors where lift speeds of up to 2,5 m/s are suitable. The dimensions of these lifts are shown in Table 2.

4.1.3 Class II lifts

Class II lifts are passenger lifts in which goods can be carried (see Figures 5 to 9 and Tables 2 and 3). Lifts for local markets are shown in Figures 10, 11 a), 11 b) and 11 c).

The dimensions of class II lifts shall be selected from those for either class I or class VI lifts. It is particularly recommended that the dimensions for the 1 000 kg lift intended for residential buildings and/or class III lifts be used for this purpose.

4.1.4 Class III lifts

Class III lifts are health-care lifts (see Figure 9 and Table 4). It should be noted that

- a) cars for 2 500 kg rated load lifts are particularly suitable for carrying persons in hospital beds of dimensions 1 000 mm × 2 300 mm, together with ancillary medical equipment and associated attendants;
- b) cars for 2 000 kg lifts are suitable for carrying beds of dimensions 1 000 mm × 2 300 mm (excluding ancillary medical equipment) but with associated attendants;
- c) cars for 1 600 kg lifts are primarily suitable for moving hospital beds of dimensions 900 mm × 2 000 mm; (excluding ancillary medical equipment) but with associated attendants;
- d) cars for 1 275 kg lifts are suitable for beds of dimensions 900 mm × 2 000 mm in nursing homes (excluding ancillary medical equipment) but with one associated attendant;

4.1.5 Class VI lifts

Class VI lifts are lifts for intensive use (see Figure 8 and Table 2).

Lifts for intensive use shall be used mainly in high-rise buildings, typically above 15 floors, where lift speeds of at least 2,5 m/s are needed. The dimensions of these lifts are shown in Table 2.

The precise load, speed and numbers of lifts should be the subject of a detailed traffic calculation.

4.2 Inner dimensions of well

4.2.1 Plan dimensions

For the incorporation of lifts in the building, the well shall have a certain free volume enclosed by a rectangular parallelepiped inscribed in the well, with vertical edges and bases formed by the bottom of the pit and the ceiling of the well.

At the planning stage, the well dimensions should be in accordance with those specified in this standard but the dimensions may be varied at a later stage if necessary to meet the requirements of a specific product.

The plan dimensions of wells should be provided by the lift contractor and define the minimum clear plumb sizes.

The purchaser's representative should take into account the constructional tolerances appropriate to any particular building technique when specifying the well structural dimensions to meet the lift contractor's dimensional requirements. The purchaser's representative, in conjunction with the builder, should ensure that the minimum clear plumb sizes specified by the lift contractor are included in the building design and are obtained in the finished work.

For the lift well plan dimensions include clear plumb tolerances (see Table 1). The dimensions b_3 and d_2 in Figures 2, 3 and 4 represent the minimum plumb requirement.

The architect or any person assuming such functions, in agreement with the builder, shall ensure that these tolerances are adequate for the specified dimensions of the finished work. Otherwise, additional tolerances shall be added to the lift well plan dimensions.

When a counterweight safety gear is required, the depths or the widths defined should be increased by up to 200 mm depending on the location of the counterweight.

4.2.1.1 Dimensional tolerances

4.2.1.1.1 General

The architect or any person assuming such functions, in agreement with the builder, should either ensure that the well dimensions are sufficient for the lift to be installed, or add additional tolerances to the nominal size dimensions for the well.

4.2.1.1.2 Well dimensions

Lifts have to move vertically through a building and the car and landing door equipment have to interconnect, therefore the plumbness of the well and the alignment of the landing openings are of paramount importance. The well shall not be built to the usually applied construction industry practices, which allow deviations from the nominal sizes as both increased and decreased dimensions. It is also important to ensure that the well is built to a high degree of verticality, i.e. plumb. Decreased dimensions are thus not acceptable to the lift industry and allowances shall be made by the architect, builder or structural engineer to accommodate the high degree of verticality needed. Failure to do so can result in significant reworking and serious delays.

The purchaser's representative, in conjunction with the builder, should ensure that dimensions in excess of the recommended minimum plumb dimensions for wells and openings do not exceed the maximum values shown in Table 1, beyond which changes in design can be necessary.

Table 1 — Limits of accuracy of well plumb dimensions

Well height (storey)	Dimensional tolerance K
< 20	+50 mm, -0 mm
> 20	+50 mm +1,0 mm per extra storey up to a maximum of 100 mm; -0 mm

NOTE 1 The dimensional tolerance K is a positive value only. Unlike other building tolerances, K cannot have a negative value.

ISO/DIS 8100-30:2017(E)

If the well is built with a negative value of K , this can require reconstruction of the well in the affected areas or extensive modifications to the lift equipment, if this is possible, resulting in delays.

NOTE 2 Figure 2 illustrates the structural limits of accuracy pertaining to single and multiple well arrangements. If the net well dimensions b_3 (well width) and d_2 (well depth) and the nominal structural entrance opening dimensions C and D are defined by plumb lines, it is essential that the actual wall does not encroach upon the space bounded by those dimensions. Dimension K in Figure 2, which is the limit of accuracy of dimensions b_3 and d_2 , should not exceed the value given in Table 1 for the relevant well height.

NOTE 3 In the case of multiple lifts situated side by side, dimension K is not applicable to the space between the plumb wells. This part of ISO 8100 and ISO 4190-2 specify a minimum of 200 mm for this space.

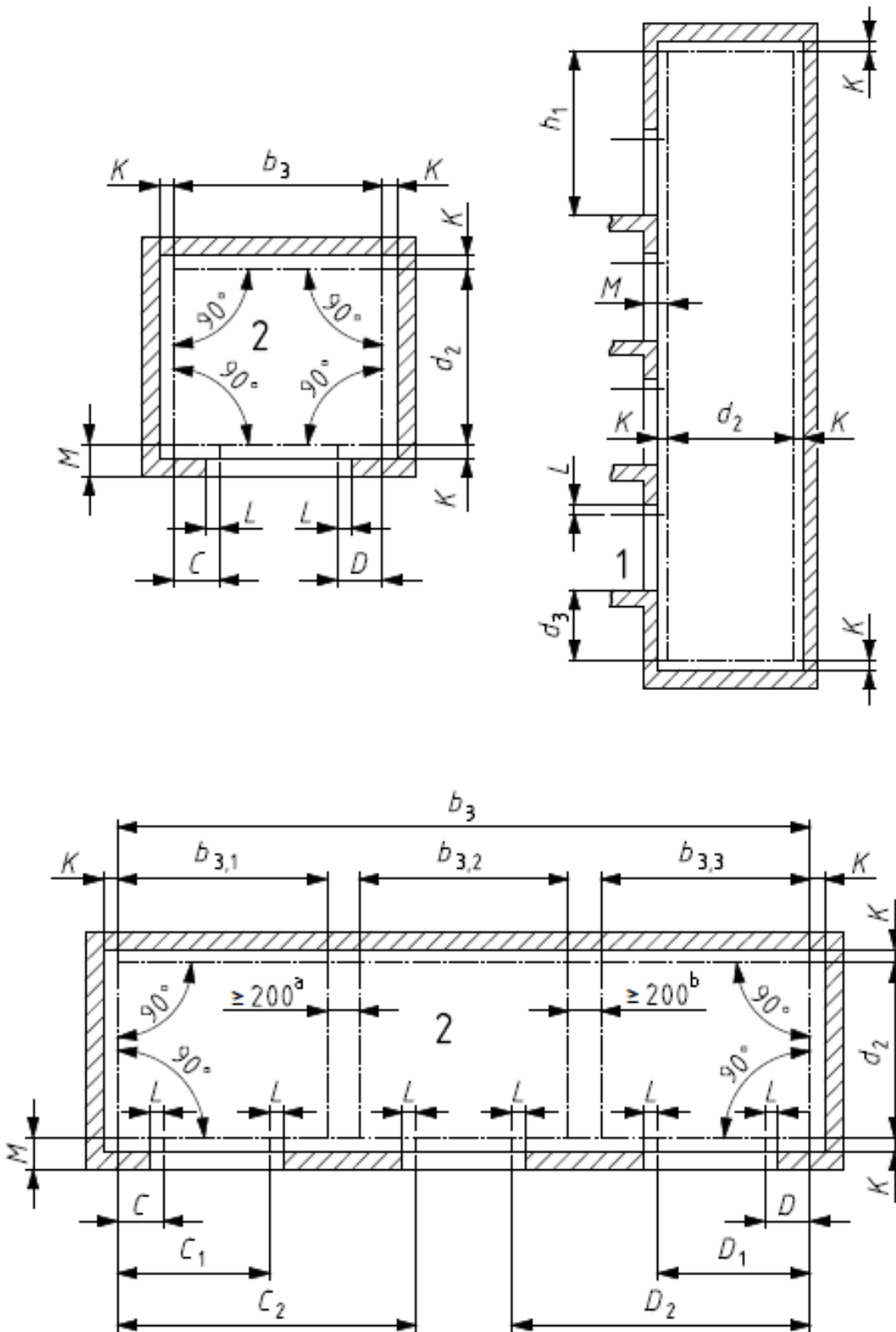

Figure 2 — Structural limits of accuracy (continued)

Key

- 1 finished floor level of landing (FFL)
- 2 lift contractor's ref. line (most prominent point of wall)
- b_3 minimum clear well dimensions (well width)
- C distance from the lift contractor's ref. line to the boundary of landing entrance (left side)
- D distance from the lift contractor's ref. line to the boundary of landing entrance (right side)
- d_3 distance from the lowest landing finished floor level to the lift contractor's ref. line at the bottom of the well (pit depth)
- h_1 distance from the top landing finished floor level to the lift contractor's ref. line at the top of the well (headroom height)
- K limit of accuracy of the well construction
- L difference between the rough opening and the finished opening
- M distance from the outside wall of the well to the lift contractor's ref. line
- a If solid dividing wall, refer to single well installation.
- b Minimum shaft trimmer width.

Figure 2 — Structural limits of accuracy

4.2.2 Individual lifts

The dimensions of the well shall have the values shown in Figures 5 to 11 a), 11 b) and 11 c).

4.2.3 Multiple lifts situated side by side

In the case of a common well, the internal dimensions shall be determined in the following manner:

- a) the total width of the common well shall be equal to the sum of the individual well widths plus the sum of the boundary widths between the wells, each boundary width being at least 200 mm;
- b) the depths of the constituent parts of the common well shall be the same as those laid down for the individual lifts.

4.2.4 Distance between landings

The recommended minimum distance between two successive landings to permit the accommodation of landing doors should be:

- 2 450 mm for a landing door height of 2 000 mm;
- 2 550 mm for a landing door height of 2 100 mm.

4.3 Dimensions of landings

4.3.1 General

The landing depth specified in subsequent clauses shall at least be maintained over the whole width of the well (individual or common).

These dimensions do not take into account the possibility of through traffic of persons not using the lifts.

4.3.2 Class I lifts particularly intended for residential buildings

These may be individual lifts or multiple lifts situated side by side.

For this category of lifts, a maximum number of four group collective lifts should be placed side by side. For hydraulic lifts, a maximum of two group collective lifts is generally recommended.

The minimum depth of the landing measured wall to wall and in the same direction as the depth(s) of the car(s) should be equal to the depth of the deepest car. However, the depth of landings served by lifts for persons with disabilities shall be at least 1 500 mm.

The turning space for a wheelchair should be considered.

4.3.3 Class I (other than those particularly intended for residential buildings), II, III and VI lifts

4.3.3.1 Individual lifts or multiple lifts situated side by side

In the case of group collective lifts, the maximum number shall be four.

The minimum depth of the landing measured wall to wall and in the same direction as the depth(s) of the car(s) should be equal to 1,5 d_1 (where d_1 is the depth of the deepest car). For group collective lifts with four lifts, other than class III, this depth shall be not less than 2 400 mm.

4.3.3.2 Lifts arranged face to face

In the case of group collective lifts, the maximum number shall be eight (2 × 4).

The distance between facing walls shall be at least equal to the sum of the depths of two facing cars. For group collective lifts, other than class III, this distance shall be not more than 4 500 mm.

4.4 Dimensions of machine room for electric lifts

Where required, at the planning stage, the machine room dimensions should be in accordance with those specified in this standard but the dimensions may be varied at a later stage if necessary to meet the requirements of a specific product. The dimensions of any machine rooms should be provided by the lift contractor. The purchaser's representative, in conjunction with the builder, should ensure that the machine room sizes specified by the lift contractor are included in the building design and are obtained in the finished work.

4.4.1 Individual lifts

Where required, the dimensions of the machine room shall be as indicated in Tables 3 and 4. Machine room heights are subject to existing national regulations.

4.4.2 Multiple lifts

4.4.2.1 Class I lifts particularly intended for residential buildings

These shall fulfil the following conditions.

4.4.2.1.1 Floor area

- a) Multiple lifts having the same rated load: the minimum floor area of the common machine room shall be equal to the sum of the minimum areas required for the individual lifts.
- b) Two lifts having different rated loads: the minimum floor area of the common machine room shall be equal to the sum of the minimum areas required for the individual lifts plus the difference between the well areas of the two lifts.
- c) A group of more than two lifts having different rated loads: the minimum floor area of the common machine room shall be equal to the sum of the minimum areas required for the individual lifts, plus the sum of the differences between the well area of the largest lift and the well areas of each of the other lifts.

4.4.2.1.2 Width

The actual dimensions shall provide a floor area at least equal to the one specified for the total area.

The minimum width of the common machine room shall be equal to the total of the common well plus a lateral extension corresponding to that appropriate to the lift with the greatest individual requirement.

4.4.2.1.3 Depth

The actual dimensions shall provide a floor area at least equal to the one specified for the total area.

The minimum depth of the common machine room shall be equal to the depth of the deepest individual well plus 2 100 mm.

4.4.2.1.4 Height

The minimum height of the common machine room shall be equal to the height of the machine room having the greatest height. Machine room heights are subject to existing national regulations.

4.4.2.2 Class I (other than those particularly intended for residential buildings), II, III and VI lifts

4.4.2.2.1 Symbols

The following symbols are used for the determination of the dimensions:

- b_4 machine room width for one single lift
- d_4 machine room depth for one single lift
- A floor area for one single lift
- b_3 well width for one single lift
- d_2 well depth for one single lift
- n total number of lifts

4.4.2.2.2 Lifts situated side by side

The total area shall be: $A + 0,9A(n - 1)$

The actual dimensions shall provide a floor area at least equal to the one specified for the total area.

Minimum width: $b_4 + (n - 1)(b_3 + 200)$

Minimum depth: d_4

4.4.2.2.3 Lifts arranged face to face

The total area shall be: $A + 0,9A(n - 1)$

The actual dimensions shall provide a floor area at least equal to the one specified for the total area.

Minimum width $b_4 + \frac{(n-1)}{2}(b_3 + 200)$

Minimum depth: $2d_2 +$ distance between the wells.

In the case of an odd number of lifts, n is rounded up to the next even number.

4.4.2.2.4 Height

The minimum height of the common machine room shall be equal to the height of the machine room having the greatest height.

Machine room heights are subject to existing national regulations.

4.5 Dimensions of machine room for hydraulic lifts

Where required, at the planning stage, the machine room dimensions should be in accordance with those specified in this standard but the dimensions may be varied at a later stage if necessary to meet the requirements of a specific product. The dimensions of any machine rooms should be provided by the lift contractor. The purchaser's representative, in conjunction with the builder, should ensure that the machine room sizes specified by the lift contractor are included in the building design and are obtained in the finished work.

4.5.1 Individual lifts

Where required, the dimensions of the machine room shall be as indicated in Tables 3 and 4. Machine room heights are subject to existing national regulations.

4.5.2 Duplex group lifts

Where required, a common machine room is recommended.

The floor area shall be as follows.

- a) Duplex group lifts having the same rated load: the minimum floor area of the common machine room shall be equal to the sum of the minimum area required for machine rooms placed behind the well of individual lifts.
- b) Duplex group lifts having different rated loads: the minimum floor area of the common machine room shall be equal to the sum of the minimum areas required for machine rooms placed behind the well of individual lifts plus the difference between the well area of the two lifts.

4.6 Arrangement of machine room (where applicable)

4.6.1 Individual or common arrangement

4.6.1.1 Where required for electric lifts, this part of ISO 8100 is based on a configuration of a machine room above the well. The lateral extension of the machine room with respect to the well (or common well) can be taken on either the right or the left of the well (see Figure 3).

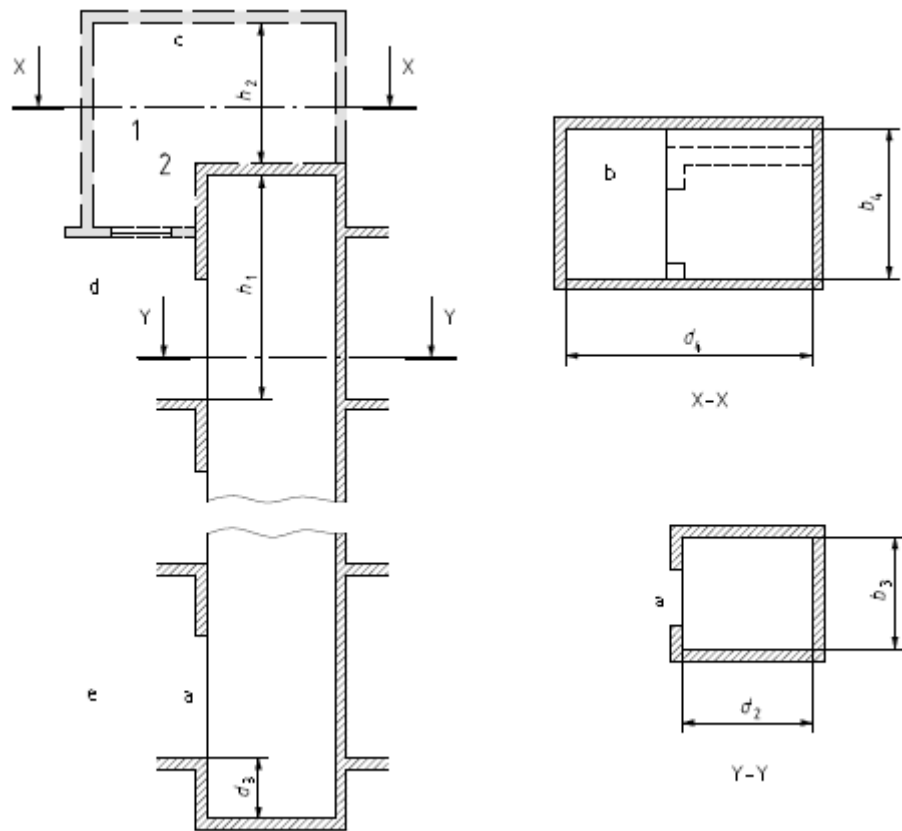

Key

- 1 machine room (where applicable)
- 2 trap door
- b_3 well width
- b_4 machine room width (where applicable)
- d_2 well depth
- d_3 pit depth
- d_4 machine room depth (where applicable)
- h_1 headroom height
- h_2 machine room height (where applicable)
- a For door details, see Figures 5 to 11 a), 11 b) and 11 c).
- b It is necessary to have an access door to the machine room although this is not indicated in the figure.
- c See 2.3.12.
- d Highest level served.
- e Lowest level served.

Figure 3 — Electric lifts with machine room

4.6.1.2 Where required for hydraulic lifts, the machine room is preferably placed beside or behind the well in the lower part of the building (see Figure 4).

Dimensions in millimetres

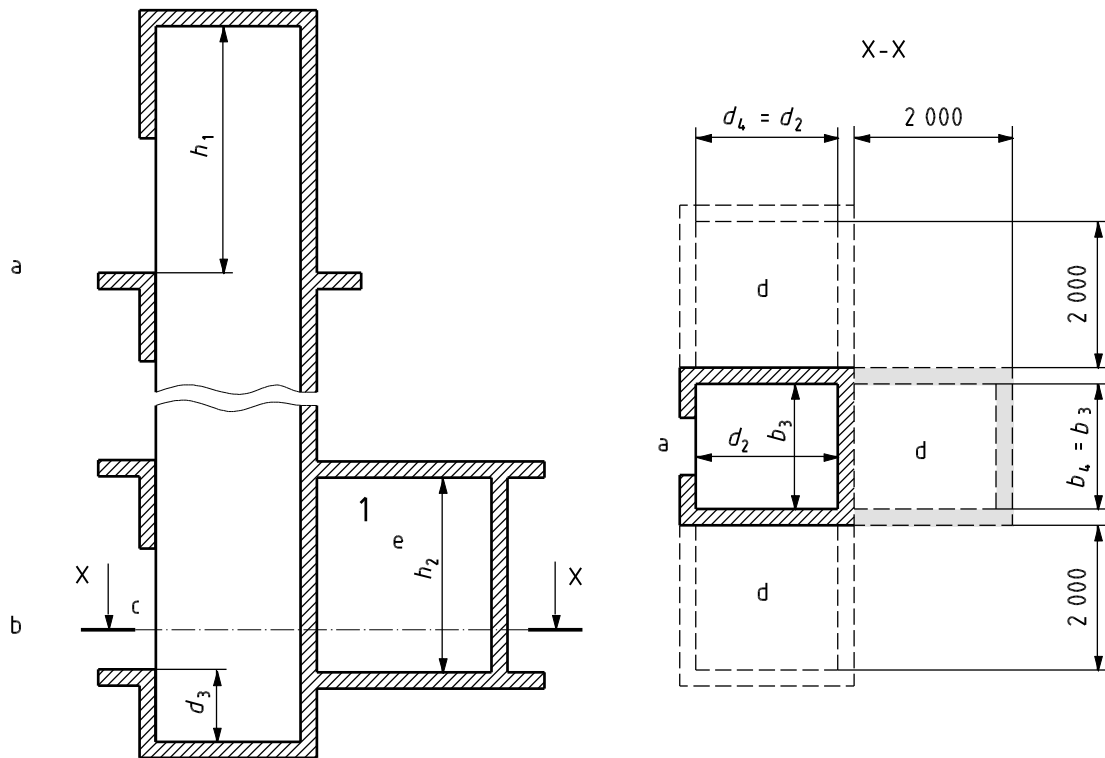

Key

- 1 machine room (where applicable)
- b_3 well width
- b_4 machine room width (where applicable)
- d_2 well depth
- d_3 pit depth
- d_4 machine room depth (where applicable)
- h_1 headroom height
- h_2 machine room height (where applicable)
- a Highest level served
- b Lowest level served
- c For door details, see Figures 5 to 11 a), 11 b) and 11 c)
- d It is necessary to have an access door to the machine room although this is not indicated in the Figure
- e See 2.3.12

Figure 4 — Hydraulic lifts with machine room

4.6.1.3 The machine room should have adequate ventilation.

4.6.2 Arrangement for individual lifts and multiple lifts side by side with common machine room

4.6.2.1 For electric lifts, the rear wall of the machine room shall be in line with the corresponding well wall (or of the deepest well) and one of the lateral walls shall be in line with the corresponding well wall (or of the common well).

The depth extension of the machine room, with respect to the well, shall be taken on the landing side.

4.6.2.2 For duplex group hydraulic lifts, the common machine room is preferably placed behind the well in the lower part of the building.

4.6.3 Arrangement for lifts face to face with a common machine room (for electric lifts only)

It is recommended that any depth extension not be greater than 0,5 m from the rear walls of the wells and be at the same level as the slab supporting the machinery.

Table 2 — Classes I, II, and VI lifts — Dimensions of headroom, pit depth, car and door height

Dimensions in millimetres

Parameter	Rated speed V_n	Lifts in residential buildings			General-purpose lifts				Intensive-use lifts				
		Rated load (mass)											
		kg											
		450	630	1 000	630	800	1 000/ 1 275	1 350	1 275	1 350	1 600	1 800	2 000
Height of car, h_4		2 200				2 300			2 400				
Height of car door and landing doors, h_3		2 000	2 100										
Pit depth ^{ae} , d_3	0,40 m/s ^b	1 400			c								
	0,63 m/s	1 400										c	
	0,75 m/s												
	1,00 m/s												
	1,50 m/s	c	1 600								c		
	1,60 m/s												
	1,75 m/s	c	1 750			c	1 750						
	2,00 m/s		2 200		c		2 200						
	2,50 m/s	c							3 200				
	3,00 m/s								3 400				
	3,50 m/s								3 800				
	4,00 m/s ^d								3 800				
5,00 m/s ^d	4 000												
6,00 m/s ^d													

Table 2 (continued)

Parameter	Rated speed V_n	Lifts in residential buildings			General-purpose lifts				Intensive-use lifts								
		Rated load (mass)															
		kg															
		450	630	1 000	630	800	1 000/ 1 275	1 350	1 275	1 350	1 600	1 800	2 000				
Headroom ^{ae} , h_1	0,40 m/s ^b	3 600			c												
	0,63 m/s	3 600			3 800		4 200		c								
	0,75 m/s	3 600			3 800		4 200										
	1,00 m/s	3 700			3 800		4 200										
	1,50 m/s	c	3 800			4 000		4 200									
	1,60 m/s		3 800			4 000		4 200									
	1,75 m/s		3 800			4 000		4 200									
	2,00 m/s	c	4 300		c	4 400											
	2,50 m/s		5 000		c	5 000	5 200	5 500									
	3,00 m/s	c												5 500			
	3,50 m/s													5 700			
	4,00 m/s ^d										5 700						
	5,00 m/s ^d										5 700						
6,00 m/s ^d	6 200																

- a Some countries require additional headroom, h_1 , and pit depth, d_3 .
- b For hydraulic lifts only.
- c Non-standard configuration.
- d Assumes advantages taken of reduced stroke buffering.
- e For pit and headroom sizes for Japan, see national legislation.

Table 3 — Classes I, II and VI lifts — Machine room dimensions

Dimensions in millimetres

	Rated speed V_n m/s	Rated load (mass)			
		320 kg to 630 kg $b_4 \times d_4$	800 kg to 1 000 kg $b_4 \times d_4$	1 275 kg to 1 600 kg $b_4 \times d_4$	1 800 kg to 2 000 kg $b_4 \times d_4$
Machine room (where needed) for electric lifts	0,63 to 1,75	2 500 × 3 700	3 200 × 4 900	3 200 × 4 900	3 000 × 5 000
	2,0 to 3,0		2 700 × 5 100	3 000 × 5 300	3 300 × 5 700
	3,5 to 6,0		3 000 × 5 700	3 000 × 5 700	3 300 × 5 700
Machine room (where needed) for Hydraulic lifts ^a	0,4 to 1,0	Width or depth of well × 2 000 mm for residential buildings			

a Site conditions and national regulations may require different machine room dimensions (b_4 , d_4 , h_2).

Table 4 — Class III lifts (Health-care lifts) — Functional dimensions

Parameter	Rated speed V_n m/s		Rated load (mass)			
			1 275	1 600	2 000	2 500
Car		Height, h_4 (mm)	2 300			
Car door and landing doors		Height, h_3 (mm)	2 100			
Pit depth, d_3	0,63		1 600		1 800	
	1,00		1 700		1 900	
	1,60		1 900		2 100	
	2,00		2 100		2 300	
	2,50		2 500			
Headroom, h_1	0,63		4 400		4 600	
	1,00		4 400		4 600	
	1,60		4 400		4 600	
	2,00		4 600		4 800	
	2,50		5 400		5 600	
Machine room ^a (where needed)	0,63 m/s to 2,50 m/s	Surface, A (m^2)	25	27	29	
		Width ^b , d_4 (mm)	3 200			3 500
		Depth ^b , d_4 (mm)	5 500		5 800	

a Site conditions and national regulations may require different machine room dimensions (b_4 , d_4 , h_2).

b b_4 and d_4 are minimum values. The actual dimensions shall provide a floor area at least equal to A .

Non-standard configuration for general-purpose or intensive-use lifts.

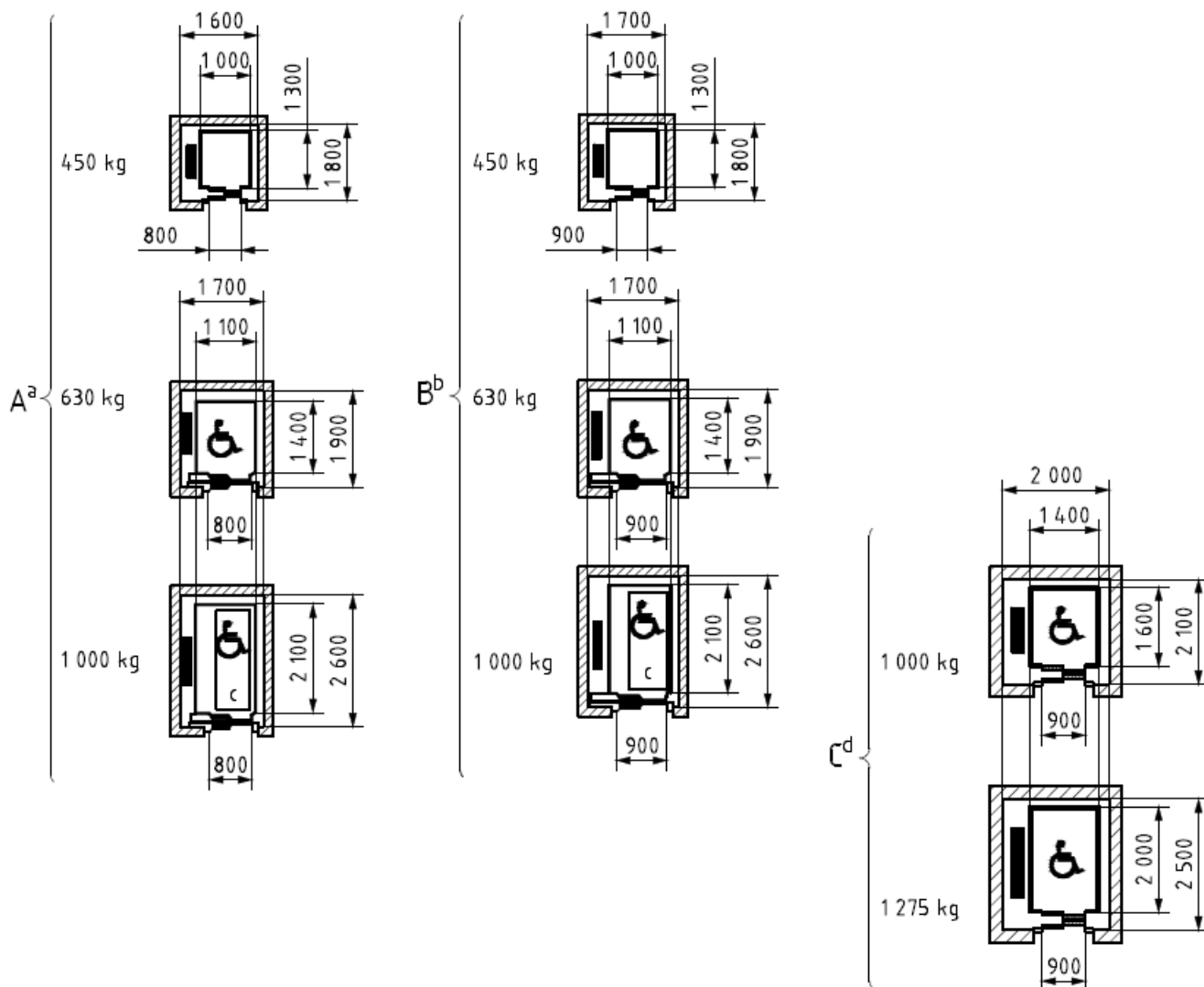

NOTE 1 Lifts suitable for speeds up to and including 2,5 m/s.

NOTE 2 The selection of 900 mm door (series B and C) is preferred on new projects and may be required by national regulations or market requirements.

NOTE 3 Series A, B and C fulfilling the requirements for accessibility by a wheelchair user carry the symbol: .

NOTE 4 Even though counterweights are shown in the diagrams, the dimensions apply to all lifts irrespective of the drive system and whether the lift has a machine room or not.

NOTE 5 450 kg sizes are not preferred for new buildings.

- a 800 mm entrances, car height 2 200 mm, entrance height 2 100 mm.
- b 900 mm entrances, car height 2 200 mm, entrance height 2 100 mm.
- c Dimensions of stretcher: 600 mm × 2 000 mm.
- d 900 mm entrances, car height 2 200 mm, entrance height 2 100 mm.

Figure 5 — Class I — Residential and general purpose lifts

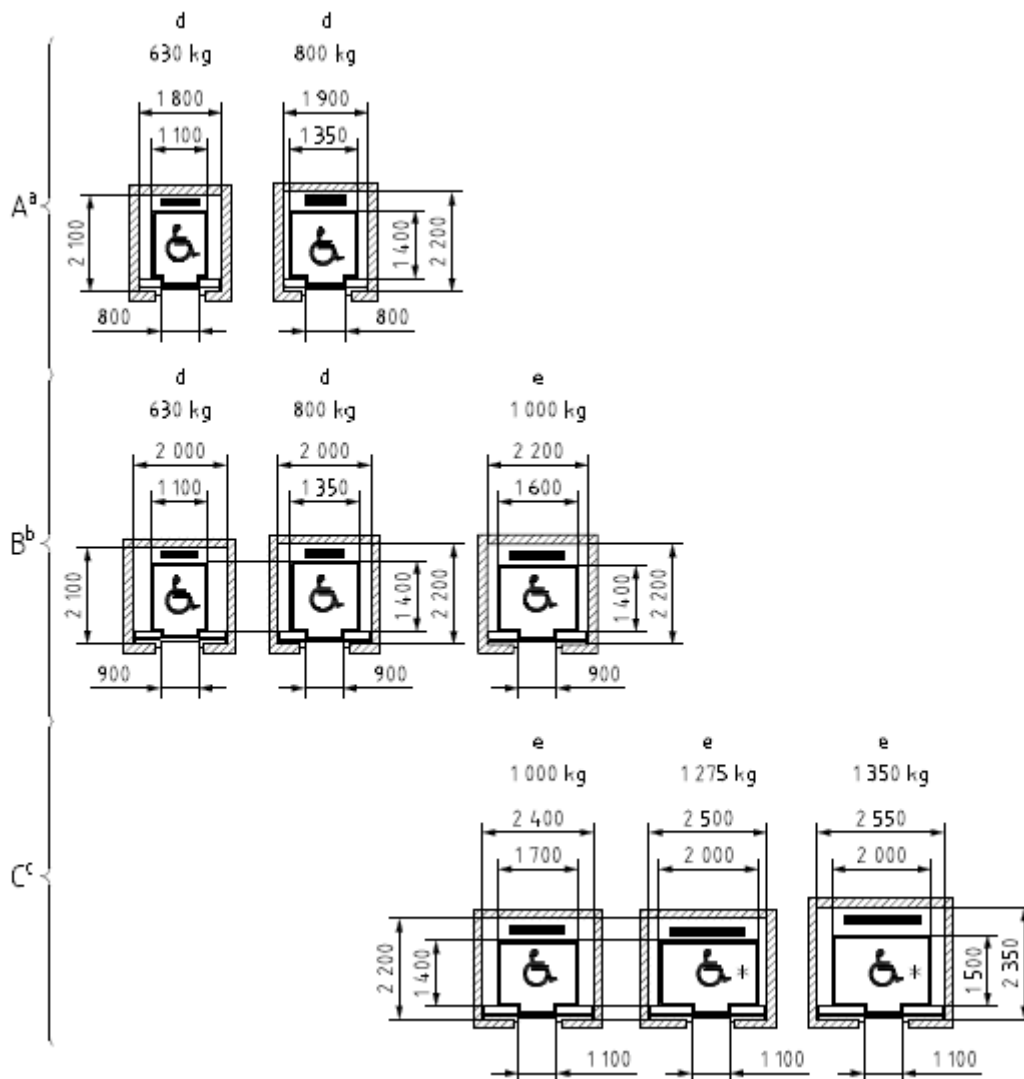

NOTE 1 Lifts suitable for speeds up to and including 2,5 m/s (when higher speeds are used, add 100 mm to the well width and depth).

NOTE 2 The selection of either series A, B or C depends on national regulations or market requirements.

NOTE 3 Series A, B and C fulfil requirements for accessibility by a wheelchair user and carry the symbol: . However, the selection of either an 800 mm or 900 mm door is subject to individual national regulations.

NOTE 4 Lifts marked thus:  * allow full manoeuvrability (3-point turn) of a wheelchair.

- a 800 mm entrances
- b 900 mm entrances
- c 1 100 mm entrances
- d Car height 2 200 mm, entrance height 2 100 mm
- e Car height 2 300 mm, entrance height 2 100 mm

Figure 6 — Class I — General-purpose lifts with counterweight to rear

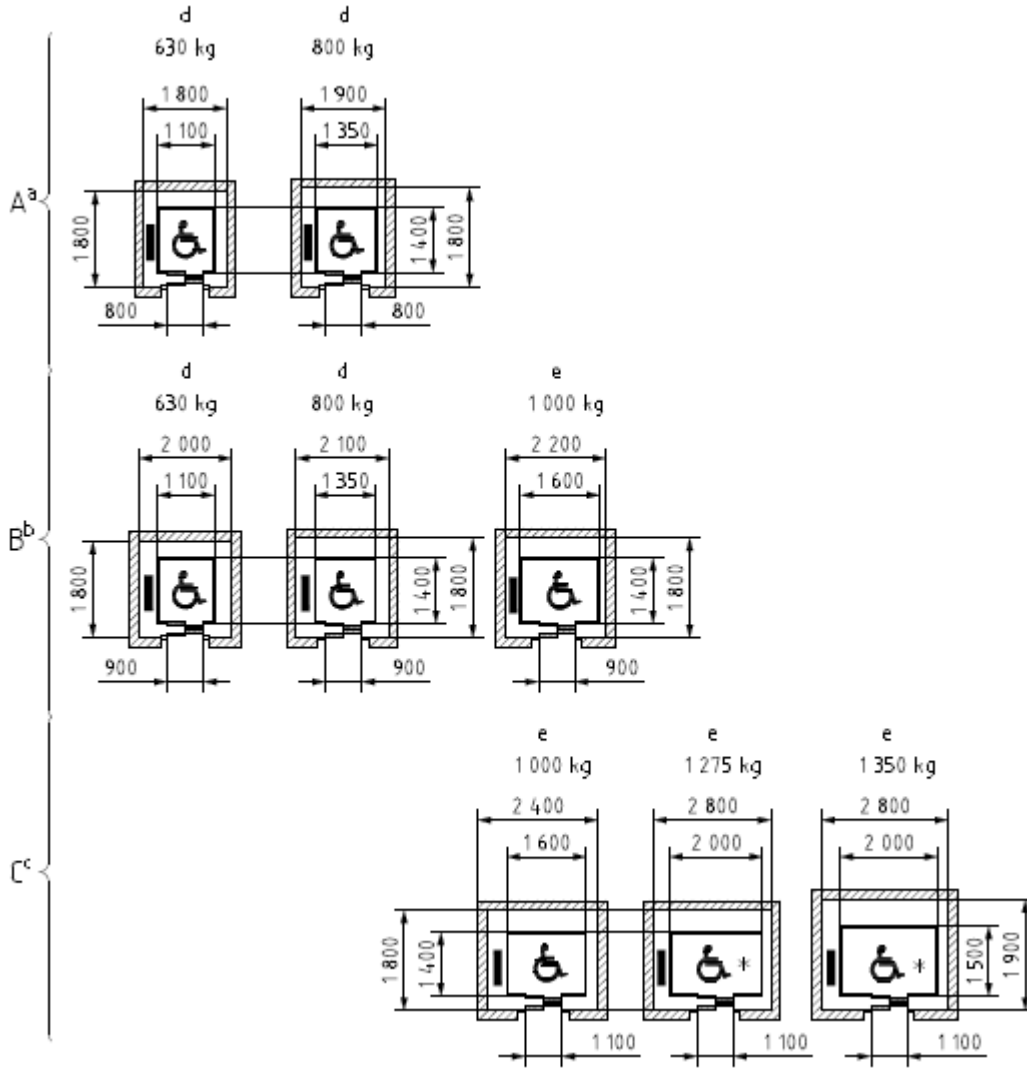

NOTE 1 Lifts suitable for speeds up to and including 2,5 m/s (when higher speeds are used, add 100 mm to the well width and depth).

NOTE 2 The selection of either series A, B or C depends on national regulations or market requirements.

NOTE 3 Series A, B and C fulfil requirements for accessibility by a wheelchair user and carry the symbol: . However, the selection of either an 800 mm or 900 mm door is subject to individual national regulations.

NOTE 4 Lifts marked thus: * allow full maneuverability (3-point turn) of a wheelchair.

- a 800 mm entrances
- b 900 mm entrances
- c 1 100 mm entrances
- d Car height 2 200 mm, entrance height 2 100 mm
- e Car height 2 300 mm, entrance height 2 100 mm

Figure 7 — Class I — General-purpose lifts with counterweight to side

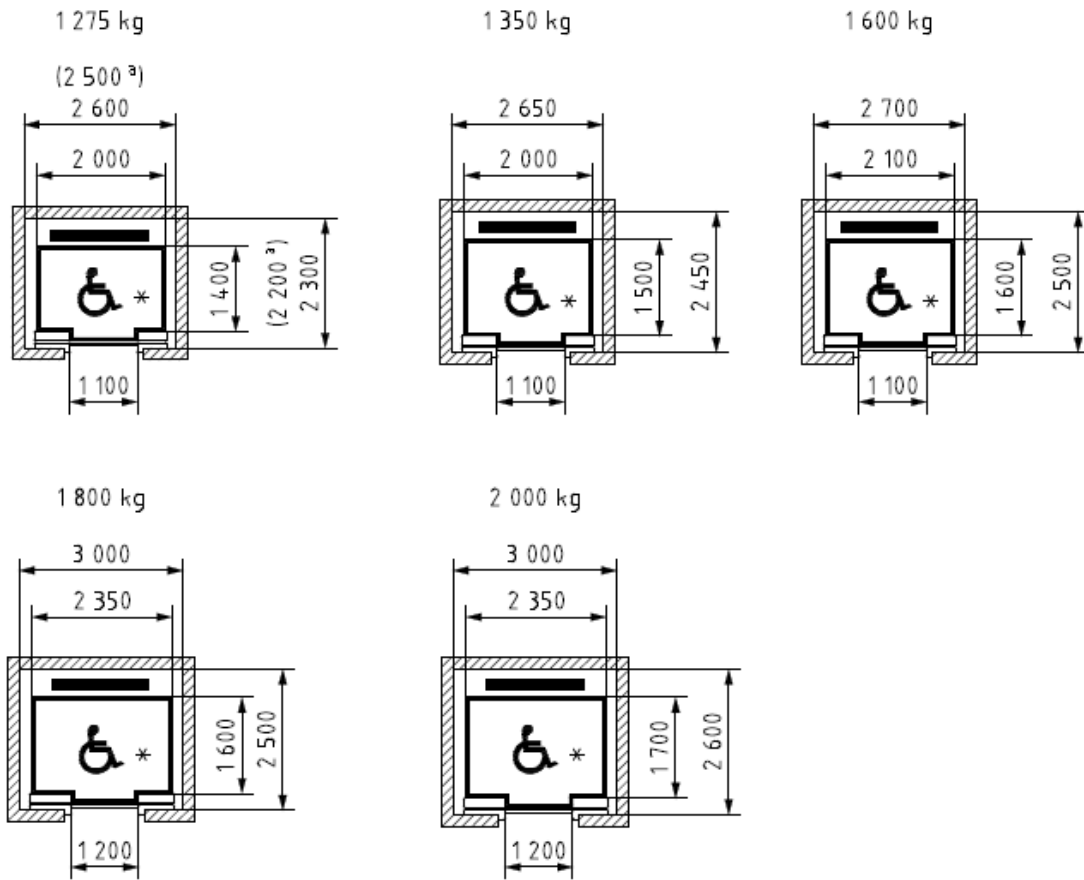

The car height shall be 2 400 mm. The entrance height shall be 2 100 mm.

NOTE 1 Lifts suitable for speeds 2,5 m/s up to and including 6,0 m/s because of having larger well sizes.

NOTE 2 Lifts marked thus  * allow full manoeuvrability (3-point turn) of a wheelchair.

a Only for lifts with 1 275 kg rated load and 2,50 m/s rated speed (see Figures 6 and 7).

Figure 8 — Class VI — Intensive-use lifts

Dimensions in millimetres

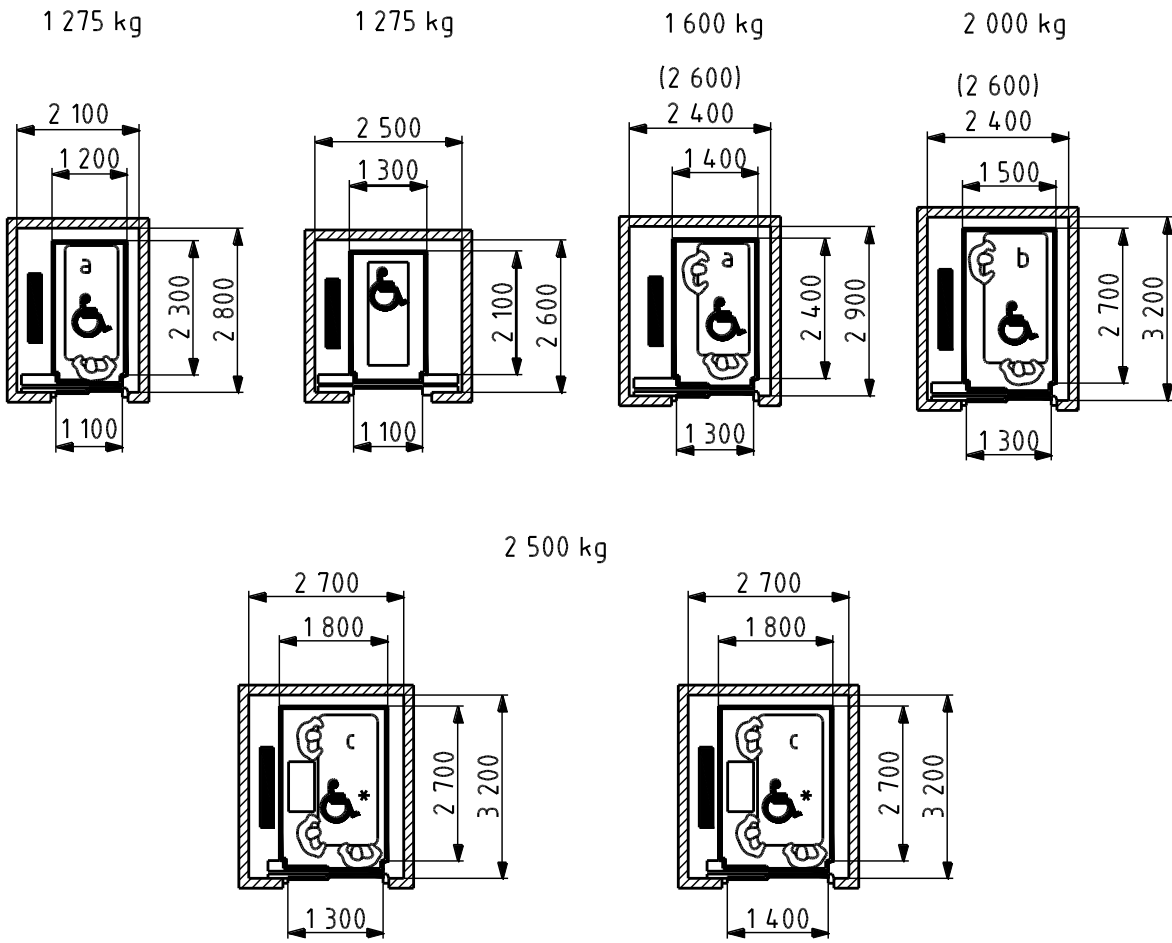

The car height shall be 2 300 mm. The entrance height shall be 2 100 mm.

NOTE 1 Lifts suitable for speeds up to and including 2,5 m/s.

NOTE 2 Well dimensions shown in brackets are valid for side acting hydraulic lifts.

NOTE 3 Lifts marked thus  allow full manoeuvrability (3-point turn) of a wheelchair.

NOTE 4 Even though counterweights are shown in the diagrams, the dimensions apply to all lifts irrespective of the drive system and whether the lift has a machine room or not.

NOTE 5 1 275 kg lift with centre-opening doors is for use in conjunction with other cars of similar door design in a group and allows the accommodation of a stretcher 600 mm x 2 000 mm. (This type of lift is used in Germany and Israel.)

- a Bed dimensions 900 mm x 2 000 mm.
- b Bed dimensions 1 000 mm x 2 300 mm.
- c Bed dimensions 1 000 mm x 2 300 mm, with additional instruments.

Figure 9 — Class III — Health-care lifts

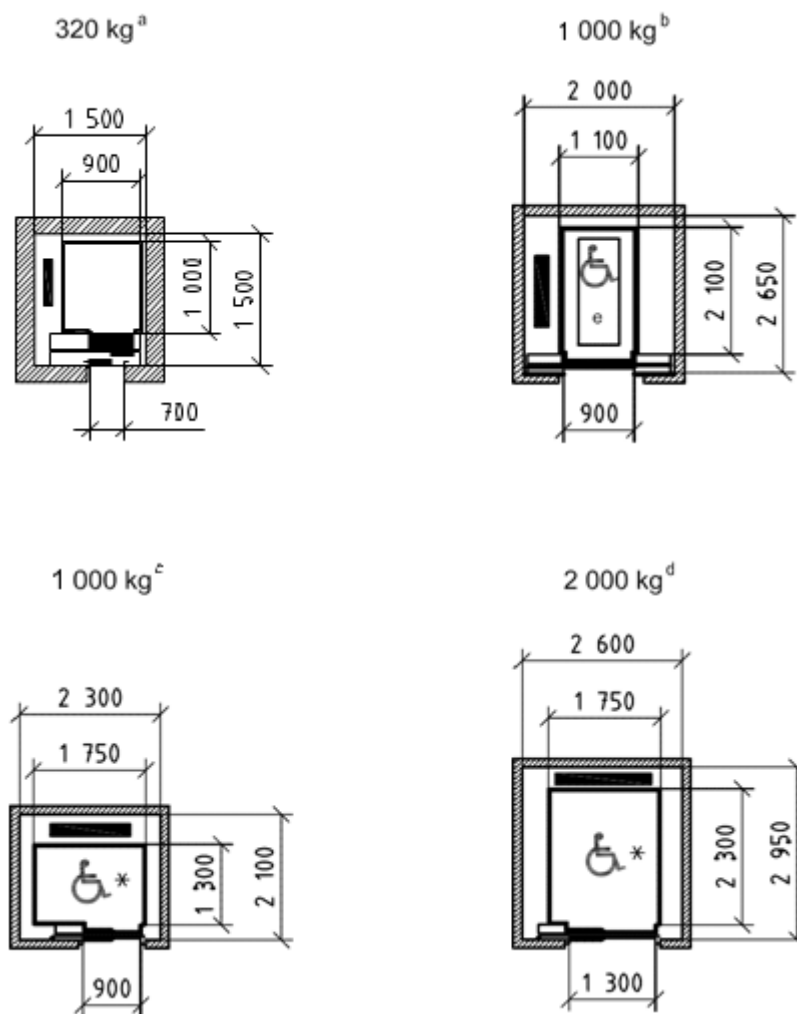

NOTE 1 Lifts suitable for speeds up to and including 2,5 m/s.

NOTE 2 Lifts marked thus * allow full manoeuvrability (3-point turn) of a wheelchair.

NOTE 3 Even though counterweights are shown in the diagrams, the dimensions apply to all lifts irrespective of the drive system.

a Car height: 2 200 mm, entrance height: 2 000 mm (Southern Europe).

b Car height: 2 200 mm, entrance height: 2 100 mm (Germany).

c Car height: 2 400 mm, entrance height: 2 100 mm (North America).

d Car height: 2 400 mm, entrance height: 2 100 mm (North America).

e Dimensions of stretcher: 600 mm × 2 000 mm.

Figure 10 — Lifts for special local markets

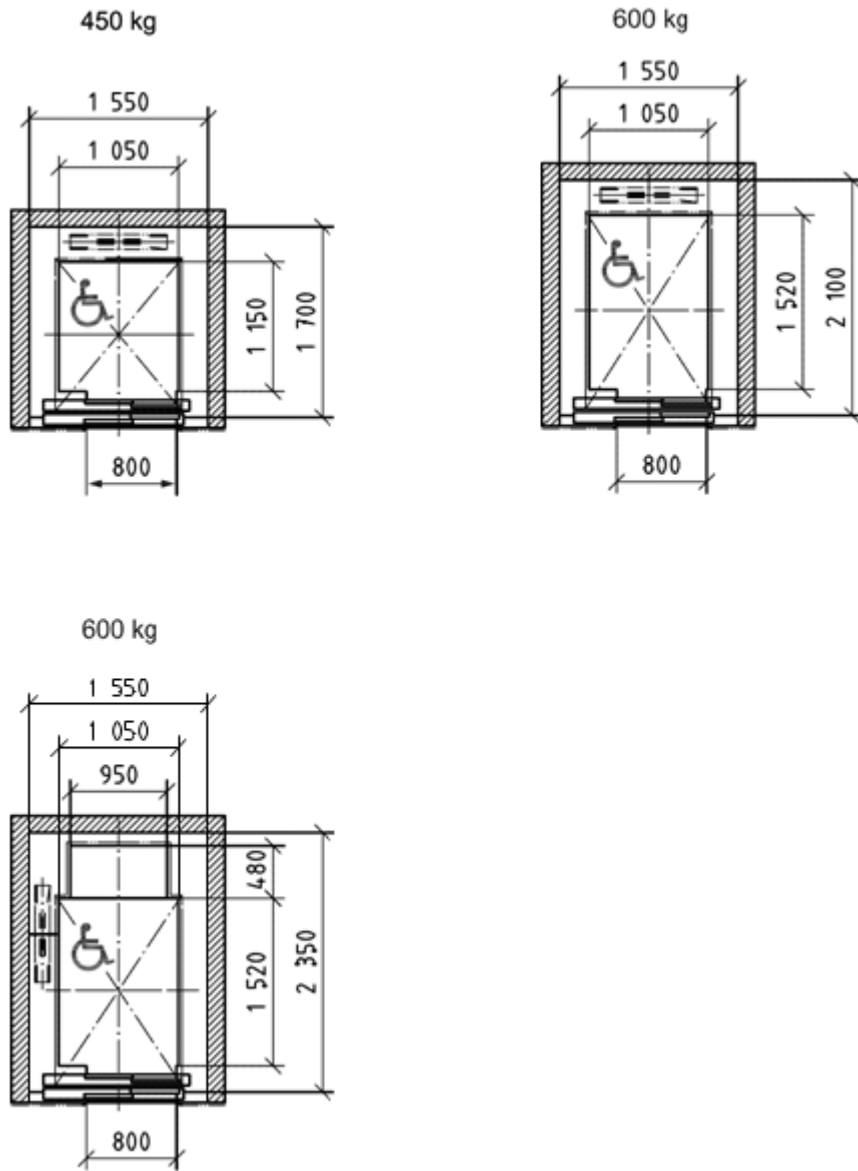

a) Residential: car height: 2 200 mm, entrance height: 2 000 mm

- NOTE 1 Japan uses two sizes of wheelchair, one size is according to ISO 7193 (700 mm x 1 200 mm); the other size is an older model (650 mm x 1 050-1 100 mm).
- NOTE 2 Dimensions are shown for conventional lifts of speed less than 1.5 m/s.
- NOTE 3 For conventional lifts of speed not less than 1.5 m/s, both well depth and well width dimensions increase by 50 mm.
- NOTE 4 For lifts without machine room of speed less than 1.5 m/s, both well depth and well width dimensions increase by 50 mm.
- NOTE 5 For lifts without machine rooms of speed not less than 1.5 m/s, both well depth and well width dimensions increase by 100 mm.

Figure 11 — Lifts for local Japanese market (continued)

Normen-Download-Beuth-VFA-Interlift e. V.-KdNr. 6363432-LfNr. 8292000001-2018-02-08 12:20

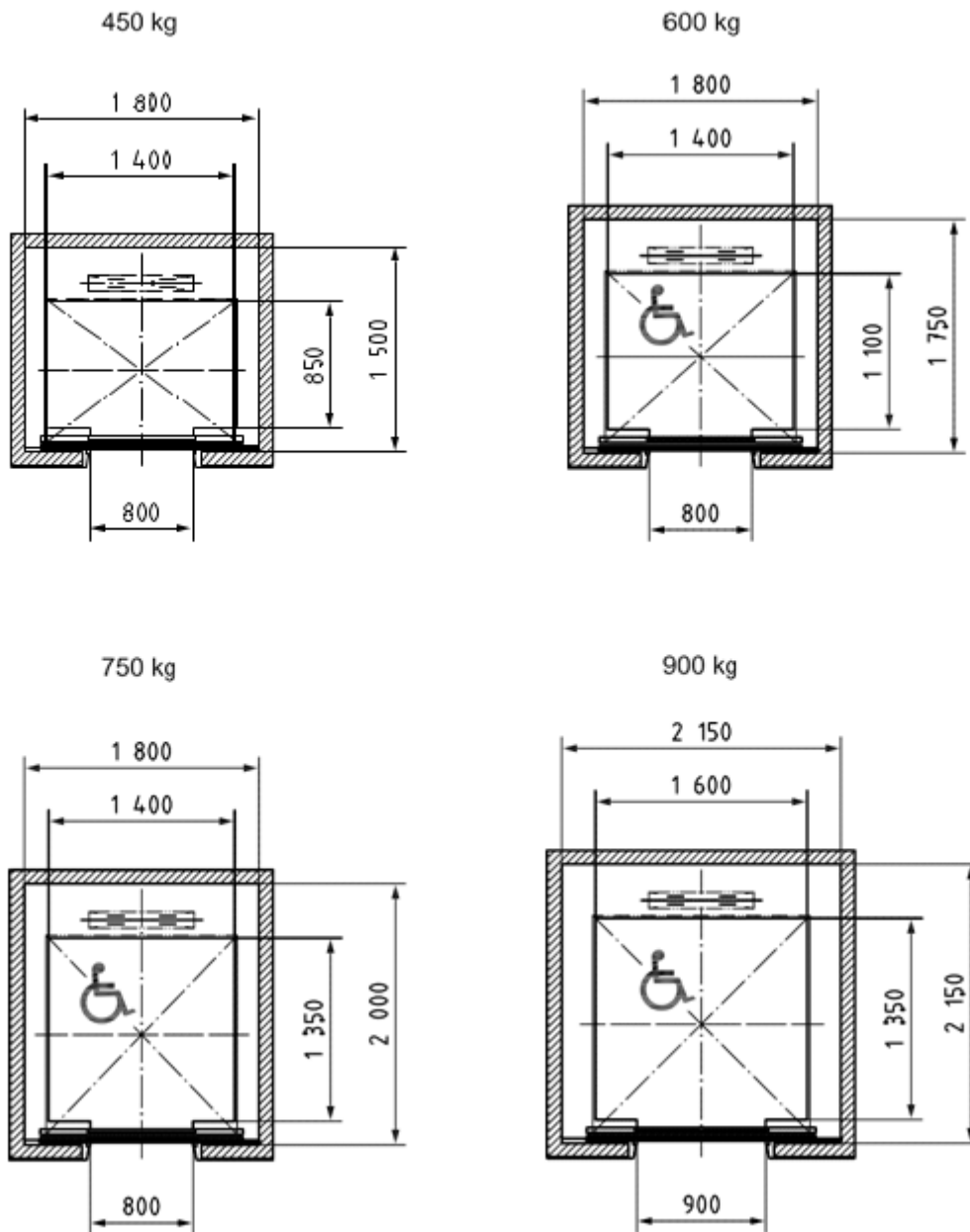

b) General purpose: car height: 2 300 mm, entrance height: 2 100 mm

- NOTE 1 Japan uses two sizes of wheelchair, one size is according to ISO 7193 (700 mm x 1 200 mm); the other size is an older model (650 mm x 1 050-1 100 mm).
- NOTE 2 Dimensions are shown for conventional lifts of speed less than 1.5 m/s with capacity 450kg, 600kg and 750kg, and conventional lifts of 900 kg capacity.
- NOTE 3 For conventional lifts of speed not less than 1.5 m/s with capacity 450 kg, 600 kg and 750 kg, both well depth and well width dimensions increase by 50 mm.
- NOTE 4 For lifts without machine room of speed less than 1.5 m/s with capacity 450kg, 600kg and 750kg, and lifts without machine room of 900 kg capacity, both well depth and well width dimensions increase by 50 mm.
- NOTE 5 For lifts without machine rooms of speed not less than 1.5 m/s with capacity 450kg, 600kg and 750kg, both well depth and well width dimensions increase by 100 mm.

Figure 11 — Lifts for local Japanese market (continued)

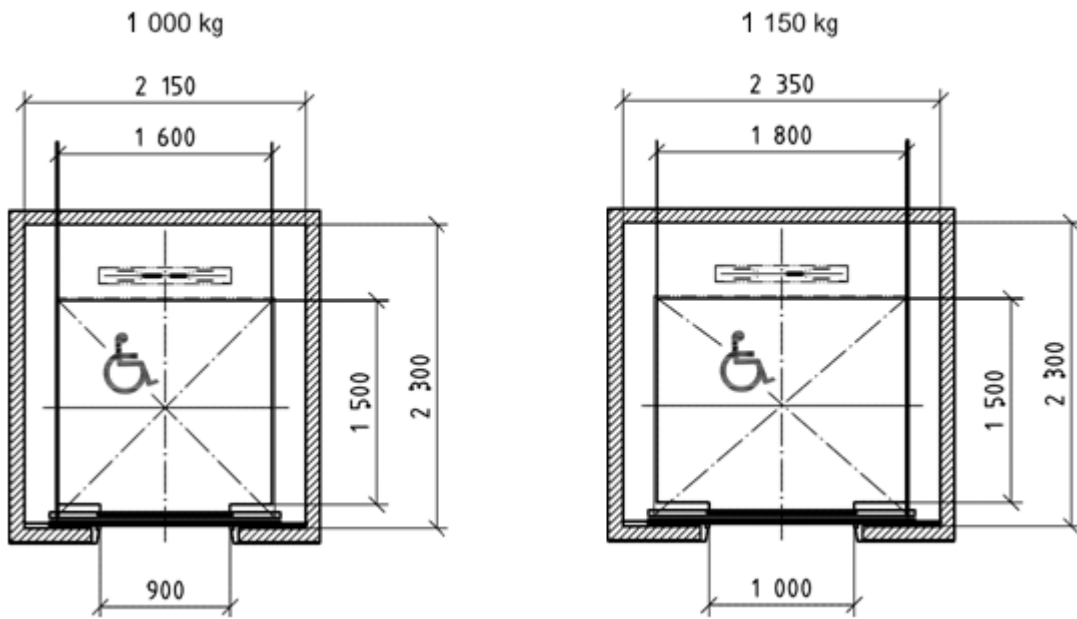

c) General purpose: car height: 2 300 mm, entrance height: 2 100 mm

NOTE 1 Japan uses two sizes of wheelchair, one size is according to ISO 7193 (700 mm x 1 200 mm); the other size is an older model (650 mm x 1 050-1 100 mm).

NOTE 2 Dimensions are shown for conventional lifts.

NOTE 3 For 1000 kg lifts without machine room, both well depth and well width dimensions increase by 50 mm.

NOTE 4 There are no standard dimension for lifts without machine room with the capacity of 1,150 kg.

Figure 11 — Lifts for local Japanese market

Bibliography

- [1] ISO 3, *Preferred numbers — Series of preferred numbers*
- [2] ISO 7193, *Wheelchairs — Maximum overall dimensions*