

DIN EN 81-50



ICS 91.140.90

Supersedes
DIN EN 81-50:2015-02

**Safety rules for the construction and installation of lifts –
Examinations and tests –
Part 50: Design rules, calculations, examinations and tests of lift
components;
English version EN 81-50:2020,
English translation of DIN EN 81-50:2020-06**

Sicherheitsregeln für die Konstruktion und den Einbau von Aufzügen –
Prüfungen –

Teil 50: Konstruktionsregeln, Berechnungen und Prüfungen von Aufzugskomponenten;
Englische Fassung EN 81-50:2020,
Englische Übersetzung von DIN EN 81-50:2020-06

Règles de sécurité pour la construction et l'installation des élévateurs –
Examens et essais –

Partie 50: Règles de conception, calculs, examens et essais des composants pour élévateurs;
Version anglaise EN 81-50:2020,
Traduction anglaise de DIN EN 81-50:2020-06

Document comprises 103 pages

Translation by DIN-Sprachendienst.

In case of doubt, the German-language original shall be considered authoritative.

A comma is used as the decimal marker.

National foreword

This standard includes safety requirements.

This document (EN 81-50:2020) has been prepared by Technical Committee CEN/TC 10 “Lifts, escalators and moving walks” (Secretariat: AFNOR, France).

The responsible German body involved in its preparation was *DIN-Normenausschuss Maschinenbau* (DIN Standards Committee Mechanical Engineering), Working Committee NA 060-33-01 AA “Lifts” of Section “Mechanical engineering”. Representatives of manufacturers and users of lifts, and of the employers' liability insurance associations contributed to this standard.

This standard contains specifications giving detail to the essential requirements set out in Annex I of the Lifts Directive 2014/33/EU, and which apply to lifts that are either first placed on the market or commissioned within the EEA. This standard serves to facilitate proof of compliance with the essential requirements of that directive.

Once this standard is cited in the Official Journal of the European Union, it is deemed a “harmonized” standard and thus, a manufacturer applying this standard may assume compliance with the requirements of the Machinery Directive (“presumption of conformity”).

For current information on this standard, please go to DIN's website (www.din.de) and search for the document number in question.

Amendments

This standard differs from DIN EN 81-50:2015-02 as follows:

- a) all external referenced standards have now been dated;
- b) a new Annex ZA has been developed in order to be aligned with the requirements of the EU Commission Standardization Request “M/549 C(2016) 5884 final”;
- c) the technical substance of the standard has not been changed.

Previous editions

DIN EN 81-1: 1978-05, 1986-10, 1999-02, 2000-05, 2010-06
DIN EN 81-1/A1: 2006-03
DIN EN 81-1/A2: 2005-01
DIN EN 81-2: 1989-07, 1999-02, 2000-05, 2010-08
DIN EN 81-2/A1: 2006-03
DIN EN 81-2/A2: 2005-01
DIN EN 81-50: 2014-11, 2015-02

English Version

**Safety rules for the construction and installation of lifts -
Examinations and tests -
Part 50: Design rules, calculations, examinations and
tests of lift components**

Règles de sécurité pour la construction et l'installation
des ascenseurs -
Examens et essais -
Partie 50: Règles de conception, calculs, examens et
essais des composants pour ascenseurs

Sicherheitsregeln für die Konstruktion und den Einbau
von Aufzügen -
Prüfungen -
Teil 50: Konstruktionsregeln, Berechnungen und
Prüfungen von Aufzugskomponenten

This European Standard was approved by CEN on 1 December 2019.

CEN members are bound to comply with the CEN/CENELEC Internal Regulations which stipulate the conditions for giving this European Standard the status of a national standard without any alteration. Up-to-date lists and bibliographical references concerning such national standards may be obtained on application to the CEN-CENELEC Management Centre or to any CEN member.

This European Standard exists in three official versions (English, French, German). A version in any other language made by translation under the responsibility of a CEN member into its own language and notified to the CEN-CENELEC Management Centre has the same status as the official versions.

CEN members are the national standards bodies of Austria, Belgium, Bulgaria, Croatia, Cyprus, Czech Republic, Denmark, Estonia, Finland, France, Germany, Greece, Hungary, Iceland, Ireland, Italy, Latvia, Lithuania, Luxembourg, Malta, Netherlands, Norway, Poland, Portugal, Republic of North Macedonia, Romania, Serbia, Slovakia, Slovenia, Spain, Sweden, Switzerland, Turkey and United Kingdom.



EUROPEAN COMMITTEE FOR STANDARDIZATION
COMITÉ EUROPÉEN DE NORMALISATION
EUROPÄISCHES KOMITEE FÜR NORMUNG

CEN-CENELEC Management Centre: Rue de la Science 23, B-1040 Brussels

Contents		Page
European foreword		5
Introduction		7
1	Scope	8
2	Normative references	8
3	Terms and definitions	9
4	List of significant hazards	9
5	Design rules, calculations, examinations and tests	11
5.1	General provisions for type examinations of safety components	11
5.1.1	Object and extent of the tests	11
5.1.2	General provisions	11
5.2	Type examination of landing and car door locking devices	12
5.2.1	General provisions	12
5.2.2	Examination and tests.....	12
5.2.3	Test particular to certain types of locking devices	15
5.2.4	Type examination certificate	15
5.3	Type examination of safety gear	15
5.3.1	General provisions	15
5.3.2	Instantaneous safety gear	16
5.3.3	Progressive safety gear	18
5.3.4	Comments	21
5.3.5	Type examination certificate	21
5.4	Type examination of overspeed governors	22
5.4.1	General provisions	22
5.4.2	Check on the characteristics of the overspeed governor	22
5.4.3	Type examination certificate	23
5.5	Type examination of buffers.....	23
5.5.1	General provisions	23
5.5.2	Samples to be submitted	24
5.5.3	Test.....	24
5.5.4	Type examination certificate	27
5.6	Type examination of safety circuits containing electronic components and/or programmable electronic systems (PESSRAL).....	28
5.6.1	General provisions	28
5.6.2	Test samples	28
5.6.3	Tests.....	29
5.6.4	Type examination certificate	30
5.7	Type examination of ascending car overspeed protection means	31
5.7.1	General provisions	31
5.7.2	Statement and test sample	31
5.7.3	Test.....	32
5.7.4	Possible modification to the adjustments	33
5.7.5	Test report	33
5.7.6	Type examination certificate	33
5.8	Type examination of unintended car movement protection means.....	34
5.8.1	General provisions	34
5.8.2	Statement and test sample	34
5.8.3	Test.....	35
5.8.4	Possible modification to the adjustments	37
5.8.5	Test report	37
5.8.6	Type examination certificate	37
5.9	Type examination of rupture valve/one-way restrictor.....	37
5.9.1	General provisions	37

5.10	Guide rails calculation	42
5.10.1	Range of calculation	42
5.10.2	Bending	42
5.10.3	Buckling	43
5.10.4	Combination of bending and compression/tension or buckling stresses	44
5.10.5	Flange bending	45
5.10.6	Deflections	46
5.11	Evaluation of traction	46
5.11.1	Introduction	46
5.11.2	Traction calculation	47
5.11.3	Formulae for a general case	51
5.12	Evaluation of safety factor on suspension ropes for electric lifts	54
5.12.1	General	54
5.12.2	Equivalent number N_{equiv} of pulleys	54
5.12.3	Safety factor	56
5.13	Calculations of rams, cylinders, rigid pipes and fittings	58
5.13.1	Calculation against over pressure	58
5.13.2	Calculations of the jacks against buckling	59
5.14	Pendulum shock tests	64
5.14.1	General	64
5.14.2	Test rig	64
5.14.3	Tests	64
5.14.4	Interpretation of the results	65
5.14.5	Test report	65
5.15	Electronic components - Failure exclusion	69
5.16	Design rules for programmable electronic systems (PESSRAL)	76
Annex A	(normative) Model form of type examination certificate	77
Annex B	(normative) Programmable electronic systems in safety related applications for lifts (PESSRAL)	78
B.1	Common measures	78
B.2	Specific measures	80
B.3	Descriptions of possible measures	84
Annex C	(informative) Example for calculation of guide rails	89
C.1	General	89
C.2	General configuration for lifts with safety gear	91
C.2.1	Safety gear operation	91
C.2.1.1	Bending stress	91
C.2.1.2	Buckling	92
C.2.1.3	Combined stress	92
C.2.1.4	Flange bending	93
C.2.1.5	Deflections	93
C.2.2	Normal operation, running	93
C.2.2.1	Bending stress	93
C.2.2.2	Buckling	93
C.2.2.3	Combined stress	93
C.2.2.4	Flange bending	93
C.2.2.5	Deflection	94

C.2.3 Normal operation, loading	94
C.2.3.1 Bending stress	94
C.2.3.2 Buckling	94
C.2.3.3 Combined stress	94
C.2.3.4 Flange bending	95
C.2.3.5 Deflections	95
Annex D (informative) Calculation of traction – Example	96
Annex E (informative) Equivalent number of pulleys N_{equiv} - Examples	98
Annex ZA (informative) Relationship between this European Standard and the essential requirements of Directive 2014/33/EU aimed to be covered	99
Bibliography	101

European foreword

This document (EN 81-50:2020) has been prepared by Technical Committee CEN/TC 10 “Lifts, escalators and moving walks”, the secretariat of which is held by AFNOR.

This European Standard shall be given the status of a national standard, either by publication of an identical text or by endorsement, at the latest by August 2020, and conflicting national standards shall be withdrawn at the latest by February 2022.

Attention is drawn to the possibility that some of the elements of this document may be the subject of patent rights. CEN shall not be held responsible for identifying any or all such patent rights.

This document supersedes EN 81-50:2014.

This document is a revision of EN 81-50:2014. Significant changes made are as follows:

- All externally referenced standards have now been dated
- A new Annex ZA has been developed in order to be aligned with the requirements of the EU Commission Standardization Request “M/549 C(2016) 5884 final”

No technical changes have been made during this revision

This standard is the culmination of the progressive development of the EN standards for lifts. Previous versions of the EN 81-1 and EN 81-2 standards incorporated into EN 81-20:2020 and EN 81-50:2020 include:

- EN 81-1:1985, Safety rules for electric lifts;
- EN 81-1:1998, Safety rules for electric lifts;
- EN 81-1:1998, Corrigendum No 1:1999;
- EN 81-1:1998/A1:2005, incorporating programmable electronic system in safety related applications for lifts;
- EN 81-1:1998/A2:2004, incorporating machine-room-less lifts;
- EN 81-1:1998+A3:2009, Incorporating unintended car movement with open doors;
- EN 81-2:1987, Safety rules for hydraulic lifts;
- EN 81-2:1998, Safety rules for hydraulic lifts;
- EN 81-2:1998, Corrigendum No 1:1999;
- EN 81-2:1998/A1:2005, incorporating programmable electronic system in safety related applications for lifts;
- EN 81-2:1998/A2:2004, incorporating machine-room-less lifts;
- EN 81-2:1998+A3:2009, incorporating unintended car movement with open doors.

The content of this standard provides the design rules, calculations, examinations and tests for lifts component, the requirements of which are specified in other EN 81 series of standards. Therefore this standard can only be used in conjunction with the standards for specific lift types, e.g. EN 81-20 for passenger and goods passenger lifts.

This standard is part of the EN 81 series of standards. The structure of the EN 81 series is described in CEN/TR 81-10.

This document has been prepared under a mandate given to CEN by the European Commission and the European Free Trade Association, and supports essential requirements of EU Directive(s).

For relationship with EU Directive(s), see informative Annex ZA, which is an integral part of this document.

According to the CEN-CENELEC Internal Regulations, the national standards organisations of the following countries are bound to implement this European Standard: Austria, Belgium, Bulgaria, Croatia, Cyprus, Czech Republic, Denmark, Estonia, Finland, France, Germany, Greece, Hungary, Iceland, Ireland, Italy, Latvia, Lithuania, Luxembourg, Malta, Netherlands, Norway, Poland, Portugal, Republic of North Macedonia, Romania, Serbia, Slovakia, Slovenia, Spain, Sweden, Switzerland, Turkey and the United Kingdom.

Introduction

The object of this standard is to define safety rules related to lifts with a view to safeguarding persons and objects against the risk of accidents associated with the user-, maintenance- and emergency operation of lifts.

Reference should be made to the respective introductions of the standards calling for the use of this standard with regard to persons and objects to be safeguarded, assumptions, principles, etc.

1 Scope

This document specifies the design rules, calculations, examinations and tests of lift components which are referred to by other standards used for the design of passenger lifts, goods passenger lifts, goods only lifts, and other similar types of lifting appliances.

2 Normative references

The following documents are referred to in the text in such a way that some or all of their content constitutes requirements of this document. For dated references, only the edition cited applies. For undated references, the latest edition of the referenced document (including any amendments) applies

EN 81-20:2020, *Safety rules for the construction and installation of lifts – Lifts for the transport of persons and goods – Part 20: Passenger and goods passenger lifts*

EN 10025 (series), *Hot rolled products of non-alloy structural steels - Technical delivery conditions*

EN 12385-5:2002, *Steel wire ropes - Safety - Part 5: Stranded ropes for lifts*

EN 60068-2-6:2008, *Environmental testing - Part 2-6: Tests - Test Fc: Vibration (sinusoidal)*

EN 60068-2-14:2009, *Environmental testing - Part 2-14: Tests - Test N: Change of temperature*

EN 60068-2-27:2009, *Environmental testing - Part 2-27: Tests - Test Ea and guidance: Shock*

EN 60112:2003, *Method for the determination of the proof and the comparative tracking indices of solid insulating materials*

EN 60664-1:2007, *Insulation coordination for equipment within low-voltage systems - Part 1: Principles, requirements and tests*

EN 60947-4-1:2010, *Low-voltage switchgear and controlgear - Part 4-1: Contactors and motor-starters - Electromechanical contactors and motor-starters*

EN 60947-5-1:2017, *Low-voltage switchgear and controlgear - Part 5-1: Control circuit devices and switching elements - Electromechanical control circuit devices*

EN 61508-1:2010, *Functional safety of electrical/electronic/programmable electronic safety-related systems - Part 1: General requirements*

EN 61508-2:2010, *Functional safety of electrical/electronic/programmable electronic safety-related systems - Part 2: Requirements for electrical/electronic/programmable electronic safety-related systems*

EN 61508-3:2010, *Functional safety of electrical/electronic/programmable electronic safety-related systems - Part 3: Software requirements*

EN 61508-7:2010, *Functional safety of electrical/electronic/programmable electronic safety-related systems - Part 7: Overview of techniques and measures*

EN ISO 12100:2010, *Safety of machinery - General principles for design - Risk assessment and risk reduction (ISO 12100:2010)*

3 Terms and definitions

For the purposes of this document, the following terms and definitions apply.

ISO and IEC maintain terminological databases for use in standardization at the following addresses:

- IEC Electropedia: available at <http://www.electropedia.org/>
- ISO Online browsing platform: available at <http://www.iso.org/obp>

3.1

approved body

organization or manufacturer, operating an approved full quality assurance system to undertake testing of safety components

3.2

safety component

component provided¹⁾ to fulfil a safety function when in use

3.3

type examination certificate

document issued by an approved body carrying out a type-examination in which it certifies that the product example under consideration complies with the provisions applicable to it

4 List of significant hazards

This clause contains all the significant hazards, hazardous situations and events, as far as they are dealt with in this standard, identified by risk assessment as significant for this type of machinery and which require action to eliminate or reduce the risk (see Table 1).

¹⁾ Under the Lifts Directive there is a list of items considered as safety components including safety gear, speed governor, landing door locks, etc. For the purposes of this standard other components may also be regarded as safety components where the aim is to certify their safe operation by type testing.

Table 1 — List of significant hazards

No	Hazards as listed in Annex B of EN ISO 12100:2010	Relevant clauses
1	Mechanical hazards due to:	
	Acceleration, deceleration (kinetic energy)	5.3; 5.4; 5.5; 5.7; 5.8; 5.9
	Approach of a moving element to a fixed part	5.2
1	Mechanical hazards due to: <i>(continued)</i>	
	Elastic elements	5.10; 5.11; 5.12; 5.13
	Falling objects	5.3; 5.4; 5.5; 5.9
	Gravity (stored energy)	5.3; 5.4; 5.5; 5.9
	Height from the ground	5.3; 5.4; 5.5; 5.9
	High pressure	5.13
	Moving elements	5.2; 5.3; 5.4; 5.5; 5.6; 5.7; 5.8; 5.9; 5.10; 5.11; 5.12; 5.13; 5.14; 5.15; 5.16
	Rotating elements	5.4; 5.11; 5.12
	Stability	5.10; 5.11; 5.12; 5.13; 5.14
	Strength	5.10; 5.11; 5.12; 5.13; 5.14
2	Electrical hazards	
	Arc	5.2; 5.4; 5.6; 5.7; 5.8; 5.15; 5.16
	Electrostatic phenomena	5.2; 5.4; 5.6; 5.7; 5.8; 5.15; 5.16
	Live parts	5.2; 5.4; 5.6; 5.7; 5.8; 5.15; 5.16
	Not enough distance to live parts under high voltage	5.2; 5.4; 5.6; 5.7; 5.8; 5.15; 5.16
	Overload	5.2; 5.4; 5.6; 5.7; 5.8; 5.15; 5.16
	Parts which have become live under faulty conditions	5.2; 5.4; 5.6; 5.7; 5.8; 5.15; 5.16
Short-circuit	5.2; 5.4; 5.6; 5.7; 5.8; 5.15; 5.16	
6	Hazards generated by radiation	
	Low frequency electromagnetic radiation	5.6; 5.15; 5.16
	Radio frequency electromagnetic radiation	5.6; 5.15; 5.16
9	Hazards associated with the environment in which the machine is used	5.2; 5.3; 5.4; 5.5; 5.6; 5.7; 5.8; 5.9; 5.10; 5.11; 5.12; 5.13; 5.14; 5.15; 5.16

5 Design rules, calculations, examinations and tests

5.1 General provisions for type examinations of safety components

5.1.1 Object and extent of the tests

The safety component/device is submitted to a test procedure to verify that insofar as construction and operation are concerned, it conforms to the requirements imposed by this standard. It shall be checked in particular that the mechanical, electrical and electronic components of the device are properly rated and that in the course of time the device does not lose its effectiveness, particularly through wear or aging. If the safety component is needed to satisfy particular requirements (waterproof, dust proof or explosion proof construction) supplementary examinations and/or tests under appropriate criteria shall be made.

5.1.2 General provisions

5.1.2.1 For the purposes of this standard it is assumed that the laboratory undertakes both the testing and the certification as an approved body. An approved body may be that of a manufacturer operating an approved full quality assurance system. In certain cases the test laboratory and the body approved for the issue of type examination certificates may be separate. In these cases the administrative procedures may differ from those described in this standard.

5.1.2.2 The application for type examination shall be made by the manufacturer of the component or their authorized representative and shall be addressed to an approved test laboratory.

5.1.2.3 The despatch of samples for examination shall be made by agreement between the laboratory and the applicant.

5.1.2.4 The applicant may attend the tests.

5.1.2.5 If the laboratory entrusted with the complete examination of one of the components requiring the supply of a type examination certificate has not available appropriate means for certain tests or examinations, it may under its responsibility have these made by other laboratories with the agreement of the applicant.

5.1.2.6 The precision of the instruments shall allow, unless specified, measurements to be made within the following accuracy:

- a) ± 1 % masses, forces, distances, speeds;
- b) ± 2 % accelerations, retardations;
- c) ± 5 % voltages, currents;
- d) ± 5 °C temperatures;
- e) recording equipment shall be capable of detecting signals, which vary in time of 0,01 s;
- f) $\pm 2,5$ % flow rate;
- g) ± 1 % pressure $P \leq 200$ kPa;
- h) ± 5 % pressure $P > 200$ kPa.

5.2 Type examination of landing and car door locking devices

5.2.1 General provisions

5.2.1.1 Field of application

These procedures are applicable to locking devices for landing and car doors. It is understood that each component taking part in the locking of doors and in the checking of the locking forms part of the locking device.

5.2.1.2 Documents to be submitted

5.2.1.2.1 Schematic arrangement drawing with description of operation

This drawing shall show clearly all the details relating to the operation and the safety of the locking device, including:

- a) the operation of the device in normal service showing the effective engagement of the locking elements and the point at which the electrical safety device operates;
- b) the operation of the device for mechanical checking of the locking position if this device exists;
- c) the control and operation of the emergency unlocking device;
- d) the type (AC and/or DC) and the rated voltage and rated current.

5.2.1.2.2 Assembly drawing with key

This drawing shall show all parts, which are important to the operation of the locking device, in particular those required to conform to requirements of this standard. A key shall indicate the list of principal parts, the type of materials used, and the characteristics of the fixing elements.

5.2.1.3 Test samples

One door locking device shall be submitted to the laboratory.

If the test is carried out on a prototype, it shall be repeated later on a production model.

If the test of the locking device is only possible when the device is mounted in the corresponding door the device shall be mounted on a complete door in working order. However, the door dimensions may be reduced by comparison with a production model, on condition that this does not falsify the test results.

5.2.2 Examination and tests

5.2.2.1 Examination of operation

This examination has the aim of verifying that the mechanical and electrical components of the locking device are operating correctly with respect to safety, and in conformity with the requirements of this standard, and the standard calling for this locking device and that the device is in conformity with the particulars provided in the application.

In particular it shall be verified that:

- a) there is at least 7 mm engagement of the locking elements before the electric safety device operates;
- b) it is not possible from positions normally accessible to persons to operate the lift with a door open or unlocked, after one single action, not forming part of the normal operation.

5.2.2.2 Mechanical tests

5.2.2.2.1 General

These tests have the purpose of verifying the strength of the mechanical locking components and the electrical components.

The sample of the locking device in its normal operating position is controlled by the devices normally used to operate it.

The sample shall be lubricated in accordance with the requirements of the manufacturer of the locking device.

When there are several possible means of control and positions of operation, the endurance test shall be made in the arrangement which is regarded as the most unfavourable from the point of view of the forces on the components.

The number of complete cycles of operation and the travel of the locking components shall be registered by mechanical or electrical counters.

5.2.2.2.2 Endurance test

The locking device shall be submitted to 1 000 000 (± 1 %) complete cycles; one cycle comprises one forward and return movement over the full travel possible in both directions.

The driving of the device shall be smooth, without shocks, and at a rate of 60 (± 10 %) cycles per minute.

During the endurance test the electrical contact of the lock shall close a resistive circuit under the rated voltage and at a current value double that of the rated current.

If the locking device is provided with a mechanical checking device for the locking pin or the position of the locking element, this device shall be submitted to an endurance test of 100 000 (± 1 %) cycles.

The driving of the device shall be smooth, without shocks, and at a rate of 60 (± 10 %) cycles per minute.

5.2.2.2.3 Static test

For locking devices intended for hinged doors, a test shall be made consisting of the application over a total period of 300 s of a static force increasing progressively to a value of 3000 N.

This force shall be applied in the opening direction of the door and in a position corresponding as far as possible to that which may be applied when a user attempts to open the door. The force applied shall be 1 000 N in the case of a locking device intended for sliding doors.

5.2.2.2.4 Dynamic test

The locking device, in the locked position, shall be submitted to a shock test in the opening direction of the door.

The shock shall correspond to the impact of a rigid mass of 4 kg falling in free fall from a height of 0,50 m.

5.2.2.3 Criteria for the mechanical tests

After the endurance test (5.2.2.2.2), the static test (5.2.2.2.3) and the dynamic test (5.2.2.2.4), there shall not be any wear, deformation or breakage, which could adversely affect safety.

5.2.2.4 Electrical test

5.2.2.4.1 Endurance test of contacts

This test is included in the endurance test laid down in 5.2.2.2.2.

5.2.2.4.2 Test of ability to break circuit

5.2.2.4.2.1 General

This test shall be carried out after the endurance test. It shall check that the ability to break a live circuit is sufficient. This test shall be made in accordance with the procedure in EN 60947-4-1:2010 and EN 60947-5-1:2017, the values of current and rated voltage serving as a basis for the tests shall be those indicated by the manufacturer of the device.

If there is nothing specified, the rated values shall be as follows:

- a) Alternating current: 230 V, 2 A;
- b) Direct current: 200 V, 2 A.

In the absence of an indication to the contrary, the capacity to break circuit shall be examined for both AC and DC conditions.

The tests shall be carried out with the locking device in the working position. If several positions are possible, the test shall be made in the most unfavourable position.

The sample tested shall be provided with covers and electric wiring as used in normal service.

5.2.2.4.2.2 AC locking devices shall open and close an electric circuit under a voltage equal to 110 % of the rated voltage 50 times, at normal speed, and at intervals of 5 s to 10 s. The contact shall remain closed for at least 0,5 s.

The circuit shall comprise a choke and a resistance in series. Its power factor shall be $0,7 \pm 0,05$ and the test current shall be 11 times the rated current indicated by the manufacturer of the device.

5.2.2.4.2.3 DC locking devices shall open and close an electric circuit under a voltage equal to 110 % of the rated voltage 20 times, at normal speed, and at intervals of 5 s to 10 s. The contact shall remain closed for at least 0,5 s.

The circuit shall comprise a choke and a resistance in series having values such that the current reaches 95 % of the steady-state value of the test current in 300 ms.

The test current shall be 110 % of the rated current indicated by the manufacturer of the device.

5.2.2.4.2.4 The tests are considered as satisfactory if no tracking or arcing is produced and if no deterioration occurs which could adversely affect safety.

5.2.2.4.3 Test for resistance to leakage currents

This test shall be made in accordance with the procedure in EN 60112:2003. The electrodes shall be connected to a source providing an AC voltage which is sinusoidal at 175 V, 50 Hz.

5.2.2.4.4 Examination of clearances and creepage distances

The clearances in air and creepage distances shall be in accordance with the requirements laid down in the standards calling for the use of this standard (e.g. EN 81-20:2020, 5.11.2.2.4).

5.2.2.4.5 Examination of the requirements appropriate to safety contacts and their accessibility

This examination shall be made taking account of the mounting position and the layout of the locking device, as appropriate.

5.2.3 Test particular to certain types of locking devices

5.2.3.1 Locking device for horizontally or vertically sliding doors with several panels

According to the requirements laid down in the standards calling for the use of this standard the devices providing direct mechanical linkage between panels (e.g. EN 81-20:2020, 5.3.14.1) or indirect mechanical linkage (e.g. EN 81-20:2020, 5.3.14.2) are considered as forming part of the locking device.

These devices shall be submitted to the tests mentioned in 5.2.2. The number of cycles per minute in such endurance tests shall be suited to the dimensions of the construction.

5.2.3.2 Flap type locking device for hinged door

If this device is provided with an electric safety device required to check the possible deformation of the flap and if, after the static test envisaged in 5.2.2.2.3 there are any doubts on the strength of the device, the load shall be increased progressively until the safety device begins to open. No component of the locking device or of the door shall be damaged or permanently deformed by the load applied.

If, after the static test, the dimensions and construction leave no doubt as to its strength, it is not necessary to proceed to the endurance test on the flap.

5.2.4 Type examination certificate

The certificate shall indicate the following:

- a) information according to Annex A;
- b) type and application of locking device;
- c) the type (AC and/or DC) and values of rated voltage and rated current;
- d) in the case of flap type door locking devices: the necessary force to actuate the electric safety device for checking the elastic deformation of the flap.

5.3 Type examination of safety gear

5.3.1 General provisions

The applicant shall state the range of use provided, i.e.:

- minimum and maximum masses;
- maximum rated speed and maximum tripping speed.

Detailed information shall be provided on the materials used, the type of guide rails and their surface condition (drawn, milled, ground).

The following documents shall be attached to the application:

- a) detailed and assembly drawings showing the construction, operation, materials used, the dimensions and tolerances on the construction components;
- b) in the case of progressive safety gear, also a load diagram relating to elastic parts.

5.3.2 Instantaneous safety gear

5.3.2.1 Test samples

Two gripping assemblies with wedges or clamps and two lengths of guide rail shall be submitted to the laboratory.

The arrangement and the fixing details for the samples shall be determined by the laboratory in accordance with the equipment that it uses.

If the same gripping assemblies can be used with different types of guide rail, a new test shall not be required if the thickness of the guide rails, the width of the grip needed for the safety gear and the surface state (drawn, milled, ground) are the same.

5.3.2.2 Test

5.3.2.2.1 Method of test

The test shall be made using a press or similar device, which moves without abrupt speed change. Measurements shall be made of:

- a) the distance travelled as a function of the force;
- b) the deformation of the safety gear block as a function of the force or as a function of the distance travelled.

5.3.2.2.2 Test procedure

The guide rail shall be moved through the safety gear.

Reference marks shall be traced onto the blocks in order to be able to measure their deformation.

The distance travelled shall be recorded as a function of the force.

After the test:

- a) the hardness of the block and the gripping element shall be compared with the original values quoted by the applicant. Other analyses may be carried out in special cases;
- b) if there is no fracture, deformations and other changes shall be examined (for example, cracks, deformations or wear of the gripping elements, appearance of the rubbed surfaces);
- c) if necessary, photographs shall be taken of the block, the gripping elements and the guide rail for evidence of deformations or fractures.

5.3.2.2.3 Documents

5.3.2.2.3.1 Two charts shall be drawn up as follows

- a) the first shall show the distance travelled as a function of the force;
- b) the other shall show the deformation of the block. It shall be done in such a way that it can be related to the first chart.

5.3.2.2.3.2 The capacity of the safety gears shall be established by integration of the area of the distance-force chart

The area of the chart to be taken into consideration shall be:

- a) the total area if there is no permanent deformation;

- b) if permanent deformation or rupture has occurred, either:
- 1) the area up to the value at which the elastic limit has been reached; or
 - 2) the area up to the value corresponding to the maximum force.

5.3.2.3 Determination of the permissible mass

5.3.2.3.1 Energy absorbed by the safety gear

A distance of free fall, calculated with reference to the maximum tripping speed of the overspeed governor fixed in the requirements laid down in the standards calling for the use of this standard (e.g. EN 81-20:2020, 5.6.2.2.1.2) shall be adopted.

The distance of free fall in metres shall be taken as: $h = \frac{v_1^2}{2 \cdot g_n} + 0,1 + 0,03$

where:

- g_n is the standard acceleration of free fall in metres per square second;
- v_1 is the tripping speed of overspeed governor in metres per second;
- 0,10 m corresponds to the distance travelled during the response time;
- 0,03 m corresponds to the travel during take-up of clearance between the gripping elements and the guide rails.

The total energy the safety gear is capable of absorbing: $2 \cdot K = (P + Q)_l \cdot g_n \cdot h$

from which: $(P + Q)_l = \frac{2 \cdot K}{g_n \cdot h}$

where:

- K, K_1, K_2 is the energy absorbed by one safety gear block in joules (calculated in accordance with the chart);
- P are the masses of the empty car and components supported by the car, i.e. part of the travelling cable, compensating ropes/chains (if any), etc. in kilograms;
- Q is the rated load in kilograms;
- $(P + Q)_l$ is the permissible mass in kilograms.

5.3.2.3.2 Permissible mass

The permissible mass in kilograms will be:

a) If the elastic limit has not been exceeded: $(P + Q)_l = \frac{2 \cdot K}{2 \cdot g_n \cdot h}$

- K is calculated by the integration of the area defined in 5.3.2.2.3.2 a);
- 2 is taken as the dividing safety coefficient.

- b) If the elastic limit has been exceeded, two calculations shall be made and the higher permissible mass may be selected:

$$1) (P + Q)_I = \frac{2 \cdot K_1}{2 \cdot g_n \cdot h}$$

K_1 is calculated by the integration of the area defined in 5.3.2.2.3.2 b) 1);

2 is taken as the dividing safety coefficient;

$$2) (P + Q)_I = \frac{2 \cdot K_2}{3,5 \cdot g_n \cdot h}$$

K_2 is calculated by the integration of the area defined in 5.3.2.2.3.2 b) 2);

3,5 is taken as the dividing safety coefficient.

5.3.3 Progressive safety gear

5.3.3.1 Statement and test sample

The applicant shall state for what mass in kilograms and tripping speed in metres per second of the overspeed governor the test will be carried out. If the safety gear shall be certified for various masses, the applicant shall specify them and indicate in addition whether adjustment is by stages or continuous.

The applicant should choose the suspended mass in kilograms by dividing the anticipated braking force in newtons by 16 to aim at an average retardation of 0,6 g_n .

A complete safety gear assembly as agreed with the laboratory, together with the number of brake shoes necessary for all the tests shall be placed at the disposal of the laboratory. The number of sets of brake shoes necessary for all the tests shall be attached. For the type of guide rail used, the length specified by the laboratory shall also be supplied.

5.3.3.2 Test

5.3.3.2.1 Method of test

5.3.3.2.1.1 The test shall be carried out in free fall. Direct or indirect measurements shall be made of:

- the total height of the fall;
- the braking distance on the guide rails;
- the sliding distance of the overspeed governor rope, or that of the device used in its place;
- the total travel of the elements forming the spring.

Measurements a) and b) shall be recorded as a function of the time.

5.3.3.2.1.2 The following shall be determined:

- a) the average braking force;
- b) the greatest instantaneous braking force;
- c) the smallest instantaneous braking force.

5.3.3.2.2 Test procedure

5.3.3.2.2.1 Safety gear certified for a single mass

The laboratory shall carry out four tests with the mass $(P+Q)_1$. Between each test the friction parts shall be allowed to return to their normal temperature.

During the tests several identical sets of friction parts may be used.

However, one set of parts shall be capable of:

- a) three tests, if the rated speed does not exceed 4 m/s;
- b) two tests, if the rated speed exceeds 4 m/s.

The height of free fall shall be calculated to correspond to the maximum tripping speed of the overspeed governor for which the safety gear can be used.

The engagements of the safety gear shall be achieved by a means allowing the tripping speed to be fixed precisely.

For example, a rope may be used, the slack of which should be carefully calculated, fixed to a sleeve which can slide with friction over a fixed smooth rope. The friction effort should be the same as the effort applied to the operating rope by the governor attached to this safety gear.

5.3.3.2.2.2 Safety gear certified for different masses

Adjustment in stages or continuous adjustment.

Two series of tests shall be carried out for:

- a) the maximum; and
- b) the minimum value applied for.

The applicant shall supply a formula, or a chart, showing the variation of the braking force as a function of a given parameter.

The laboratory shall verify by suitable means (in the absence of anything better, by a third series of tests for intermediary points) the validity of the supplied formula.

5.3.3.2.3 Determination of the braking force of the safety gear

5.3.3.2.3.1 Safety gear certified for a single mass

The braking force of which the safety gear is capable for the given adjustment and the type of guide rail is taken as equal to the average of the average braking forces determined during the tests. Each test shall be made on an unused section of guide rail.

A check shall be made that the average values determined during the tests lie within a range of $\pm 25\%$ in relation to the value of the braking force defined above.

NOTE Tests have shown that the coefficient of friction could be considerably reduced if several successive tests were carried out on the same area of a machined guide rail. This is attributed to a modification in the surface condition during successive safety gear operations.

It is accepted that, on an installation, an inadvertent operation of the safety gear would have every chance of occurring at an unused section of guide rail.

It is necessary to consider that if, by chance, this were not the case, the braking force would have a lower value until an unused portion of guide rail surface was reached. Hence, greater sliding than normal.

This is a further reason for not permitting any adjustment causing too small a retardation at the beginning.

5.3.3.2.3.2 Safety gear certified for different masses

Adjustment in stages or continuous adjustment.

The braking force of which the safety gear is capable shall be calculated as laid down in 5.3.3.2.3.1 for the maximum and minimum values applied for.

5.3.3.2.4 Checking after the tests

After the tests it shall be checked:

- a) the hardness of the block and the gripping elements shall be compared with the original values submitted by the applicant;
- b) the deformations and modifications (for example, cracks, deformations or wear of the gripping elements, appearance of the rubbing surfaces) shall be checked;
- c) if necessary, the safety gear assembly, the gripping elements and the guide rails shall be photographed in order to reveal deformations or fractures.

5.3.3.3 Calculation of the permissible mass

5.3.3.3.1 Safety gear certified for a single mass

The permissible mass shall be calculated using the following formula:

$$(P + Q)_l = \frac{F_B}{16}$$

where

- F_B is the braking force in newtons determined in accordance with 5.3.3.2.3;
- P is the masses of the empty car and components supported by the car, i.e. part of the travelling cable, compensating ropes/chains (if any), etc. in kilograms;
- Q is the rated load in kilograms;
- $(P + Q)_l$ is the permissible mass in kilograms.

If the calculated permissible mass is larger than the tested mass, the tested mass may be taken as permissible mass provided that the average retardation of each test did not exceed $1 g_n$.

5.3.3.3.2 Safety gear certified for different masses

5.3.3.3.2.1 Adjustment in stages

The permissible mass shall be calculated for each adjustment as laid down in 5.3.3.3.1.

5.3.3.3.2.2 Continuous adjustment

The permissible mass shall be calculated as laid down in 5.3.3.3.1 for the maximum and minimum values applied for and in accordance with the formula supplied for the intermediate adjustments.

5.3.3.4 Possible modification to the adjustments

If, during the tests, the values found differ by more than 20 % from those expected by the applicant, other tests may be made with their agreement, after modification of the adjustments if necessary.

5.3.4 Comments

a) Applicable mass

The applicable mass used for a lift shall not exceed the permissible mass for instantaneous safety gear.

In the case of progressive safety gear, the mass stated may differ from the applicable mass stated in 5.3.3.3 by $\pm 7,5\%$. It is accepted in these conditions that the requirements laid down in the standards calling for the use of this standard (e.g. EN 81-20:2020, 5.6.2.1) are met on the installation, notwithstanding the usual tolerances on the thickness of the guide rails, the surface conditions, etc.;

- b) To evaluate the validity of welded parts, reference shall be made to standards on this subject;
- c) A check shall be made that the possible travel of the gripping elements is sufficient under the most unfavourable conditions (accumulation of manufacturing tolerances);
- d) The friction parts shall be suitably retained so that it can be certain that they will be in place at the moment of operation;
- e) In the case of a progressive type safety gear, it shall be checked that the travel of the components forming the spring is sufficient.

5.3.5 Type examination certificate

The certificate shall indicate the following:

- a) information according to Annex A;
- b) type and application of safety gear;
- c) the limits of the permissible masses (see 5.3.4 a);
- d) the tripping speed of the overspeed governor;
- e) the type of guide rail;
- f) the permissible thickness of the guide rail blade;
- g) the minimum width of the gripping areas;

and, for progressive safety gear only:

- h) the surface condition of the guide rails (drawn, milled, ground);
- i) the state of lubrication of the guide rails. If they are lubricated, the category and specification of the lubricant.

5.4 Type examination of overspeed governors

5.4.1 General provisions

The applicant shall indicate the following to the laboratory:

- a) the type (or the types) of safety gear which will be operated by the governor;
- b) the maximum and minimum rated speeds of lifts for which the governor may be used;
- c) the anticipated value of the tensile force produced in the rope by the overspeed governor when tripped.

Detailed and assembly drawings showing the construction, operation, materials used, the dimensions and tolerances on the construction components shall be attached to the application.

5.4.2 Check on the characteristics of the overspeed governor

5.4.2.1 Test samples

The following shall be submitted to the laboratory:

- a) one overspeed governor;
- b) one rope of the type used for the overspeed governor and in the normal condition in which it should be installed. The length to be supplied is fixed by the laboratory;
- c) a tensioning pulley assembly of the type used for the overspeed governor.

5.4.2.2 Test

5.4.2.2.1 Method of test

The following shall be checked:

- a) the speed of tripping is within the range stated by the applicant;
- b) the operation of the electric safety device called for in the standards calling for the use of this standard (e.g. EN 81-20:2020, 5.6.2.2.1.6 a) causing the machine to stop, if this device is mounted on the overspeed governor;
- c) the operation of the electric safety device called for in the standards calling for the use of this standard (e.g. EN 81-20:2020, 5.6.2.2.1.6 b) preventing all movement of the lift when the overspeed governor is tripped;
- d) the tensile force produced in the rope by the overspeed governor when tripped.

5.4.2.2.2 Test procedure

At least twenty tests shall be made in the speed range for tripping corresponding to the range of rated speeds of the lift, indicated in 5.4.1 b).

The majority of tests should be made at the extreme values of the range.

The acceleration to reach the tripping speed of the overspeed governor should be as low as possible, in order to eliminate the effects of inertia.

In addition a minimum of two tests shall be made with an acceleration of between $0,9 g_n$ and $1 g_n$ in order to simulate a free fall situation and prove no deterioration of the governor has been caused.

5.4.2.2.3 Interpretation of the test results

In the course of twenty tests the tripping speeds shall lie within the limits laid down for overspeed governors in the standards calling for the use of this standard.

NOTE If the limits laid down are exceeded, an adjustment may be made by the manufacturer of the component and 20 new tests carried out.

In the course of the twenty tests the operation of the devices for which the test is required in 5.4.2.2.1 b) and c) shall occur within the limits laid down in the standards calling for the use of this standard (e.g. EN 81-20:2020, 5.6.2.2.1.6 a) and 5.6.2.2.1.6 b).

The tensile force in the rope produced by the overspeed governor when tripped shall be at least 300 N or any higher value which is specified by the applicant.

Unless otherwise requested by the manufacturer of the device and specified in the test report, the arc of engagement should be 180° .

In the case of a device, which operates by gripping the rope, it should be checked that there is no permanent deformation of the rope.

5.4.3 Type examination certificate

The certificate shall indicate the following:

- a) information according to Annex A;
- b) type and application of overspeed governor;
- c) the maximum and minimum rated speeds of the lift for which the overspeed governor may be used;
- d) the diameter of the rope to be used and its construction;
- e) in the case of an overspeed governor with traction pulley, the minimum tensioning force;
- f) the tensile force in the rope which can be produced by the overspeed governor when tripped.

5.5 Type examination of buffers

5.5.1 General provisions

The applicant shall state the range of use provided, i.e. maximum impact speed, minimum and maximum masses. The following shall be attached to the application:

- a) Detailed and assembly drawings showing the construction, operation, materials used, the dimensions and tolerances on the construction components.

In the case of hydraulic buffers, the graduation (openings for the passage of the liquid), in particular, shall be shown as a function of the stroke of the buffer;

- b) Specifications for the liquid used;
- c) Information regarding environmental conditions for use (temperature, humidity, pollution, etc.) and of life-cycle (aging, rejection criteria).

5.5.2 Samples to be submitted

The following shall be submitted to the laboratory:

- a) one buffer;
- b) in the case of hydraulic buffers, the necessary liquid sent separately.

5.5.3 Test

5.5.3.1 Energy dissipation buffers

5.5.3.1.1 Test procedure

The buffer shall be tested with the aid of weights, corresponding to the minimum and maximum masses, falling in free fall to reach at the moment of impact the maximum speed called for.

The speed shall be recorded at least from the moment of impact of the weights. The acceleration and the retardation shall be determined as a function of time throughout the movement of the weights.

5.5.3.1.2 Equipment to be used

5.5.3.1.2.1 Weights falling in free fall

The weights shall correspond with the tolerances of 5.1.2.6, to the maximum and minimum masses. They shall be guided vertically with the minimum of friction possible.

5.5.3.1.2.2 Recording equipment

The recording equipment shall be able to detect signals with the tolerances of 5.1.2.6. The measuring chain, including the recording device for the recording of measured values as a function of time, shall be designed with a system frequency of at least 1000 Hz.

5.5.3.1.2.3 Measurement of speed

The speed shall be recorded at least from the moment of impact of the weights on the buffer or throughout the travel of the weights with the tolerances of 5.1.2.6.

5.5.3.1.2.4 Measurement of the retardation

If there is a device for measuring retardation (see 5.5.3.1.1), it shall be placed as near as possible to the axis of the buffer, and shall be capable of measurement with the tolerances of 5.1.2.6.

5.5.3.1.2.5 Measurement of time

Time pulses of duration of 0,01 s shall be recorded and measured with the tolerances of 5.1.2.6.

5.5.3.1.3 Ambient temperature

The ambient temperature shall lie between + 15 °C and + 25 °C.

The temperature of the liquid shall be measured with the tolerances of 5.1.2.6.

5.5.3.1.4 Mounting of the buffer

The buffer shall be placed and fixed in the same manner as in normal service.

5.5.3.1.5 Filling of the buffer

The buffer shall be filled up to the mark indicated following the instructions of the component manufacturer.

5.5.3.1.6 Checks

5.5.3.1.6.1 Checking of retardation

The height of free fall of the weights shall be chosen in such a way that the speed at the moment of impact corresponds to the maximum impact speed stipulated in the application.

The retardation shall conform to the requirements of the standard calling for this device (e.g. EN 81-20:2020, 5.8.2.2.3).

The creeping at the end of the buffer stroke for calculation of the average retardation shall be ignored where the retardation is below $0,5 \text{ m/s}^2$.

A first test shall be made with maximum mass with a check on the retardation.

A second test shall be made with minimum mass with a check on the retardation.

5.5.3.1.6.2 Checking of the return of the buffer to the normal position

After each test the buffer shall be held in the completely compressed position for 5 min. The buffer shall then be freed to permit its return to its normal extended position.

When the buffer is of a type with spring or gravity return, the position of complete return shall be reached in a maximum period of 120 s.

Before proceeding to another retardation test there shall be a delay of 30 min to permit the liquid to return to the tank and for bubbles of air to escape.

5.5.3.1.6.3 Checking of the liquid losses

The level of liquid shall be checked after having made the two retardation tests required in 5.5.3.1.6.1, and after an interval of 30 min the level of liquid shall again be sufficient to ensure normal operation of the buffer.

5.5.3.1.6.4 Checking of the condition of the buffer after tests

After the two retardation tests required in 5.5.3.1.6.1, no part of the buffer shall show any permanent deformation or be damaged so that its condition shall guarantee normal operation.

5.5.3.1.7 Procedure in the case of tests failing the requirements

When the test results are not satisfactory with the minimum and maximum masses appearing in the application, the laboratory may, in agreement with the applicant, establish the acceptable limits.

5.5.3.2 Energy accumulation buffers with non linear characteristics

5.5.3.2.1 Test procedure

The buffer shall be tested with the aid of masses falling in free fall from a height to reach at the moment of impact the maximum speed called for, but not less than $0,8 \text{ m/s}$.

The falling distance, the speed, the acceleration and retardation shall be recorded from the moment of release of the weight to the complete standstill.

The masses shall correspond to the maximum and minimum masses called for. They shall be guided vertically with a minimum of friction possible, so that at the moment of impact at least $0,9 g_n$ are reached.

5.5.3.2.2 Equipment to be used

The equipment shall correspond to 5.5.3.1.2.

5.5.3.2.3 Ambient temperature

The ambient temperature shall lie between + 15 °C and + 25 °C.

5.5.3.2.4 Mounting of the buffer

The buffer shall be placed and fixed in the same manner as in normal service.

5.5.3.2.5 Number of tests

Three tests shall be made with:

- a) The maximum mass;
- b) The minimum mass called for.

The time delay between two consecutive tests shall lie between 5 min and 30 min.

With the three tests with maximum mass the value of reference of the buffer force at a stroke equal to 50 % of the real height of the buffer given by the applicant shall not vary by more than 5 %. With the tests with minimum mass this shall be observed in analogy.

Within 30 min before the test the buffer shall be once loaded either statically or dynamically in order to prevent further settlement and deviations during the test.

5.5.3.2.6 Checks

5.5.3.2.6.1 Checking of retardation

The retardation "a" (e.g. EN 81-20:2020, 5.8.2.1.2.1) shall conform to the following requirements:

- a) The retardation will be evaluated taking into account the time between the first two absolute minima of the retardation (see Figure 1). The retardation shall not exceed the maximum as required by the standard calling for this device.
- b) Peaks of retardation shall not exceed the maximum as required by the standard calling for this device.
- c) The peak retardation shall not exceed the maximum as required in the standard calling for this device.
- d) The return speed shall not exceed the maximum as required in the standard calling for this device.

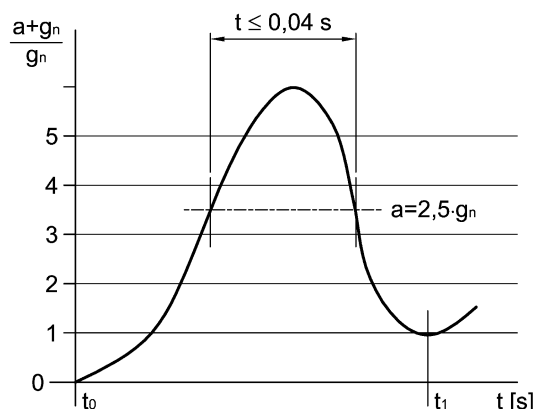

Key

- t_0 moment of hitting the buffer (first absolute minimum)
- t_1 second absolute minimum

Figure 1 — Retardation graph - Example using EN 81-20:2020 requirements

5.5.3.2.6.2 Checking of the condition of the buffer after tests

After the tests with the maximum mass no part of the buffer shall show any permanent deformation or be damaged so that its condition shall guarantee normal operation.

5.5.3.2.7 Procedure in the case of tests failing the requirements

When the test results are not satisfactory with the minimum and maximum masses appearing in the application, the laboratory may, in agreement with the applicant, establish the acceptable limits.

5.5.4 Type examination certificate

The certificate shall indicate the following:

- a) information according to Annex A;
- b) type and application of buffer;
- c) dimensions of buffer;
- d) the maximum impact speed;
- e) the maximum mass;
- f) the minimum mass;
- g) kind of fixation;
- h) the specification of the liquid in the case of hydraulic buffers;
- i) environmental conditions for use according to instructions of the manufacturer (temperature, humidity, pollution, etc.).

5.6 Type examination of safety circuits containing electronic components and/or programmable electronic systems (PESSRAL)

5.6.1 General provisions

5.6.1.1 General

For safety circuits containing electronic components, laboratory tests are necessary because practical checks on site, by inspectors, are impossible.

In the following, mention is made to printed circuit board. If a safety circuit is not assembled in such a manner, then the equivalent assembly shall be assumed.

5.6.1.2 Safety circuits containing electronic components

The applicant shall indicate to the laboratory:

- a) identification on the board;
- b) environmental working conditions;
- c) listing of used components;
- d) layout of the printed circuit board;
- e) layout of the hybrids and marks of the tracks used in safety circuits;
- f) function description;
- g) electrical wiring diagram, including input and output definitions of the board;
- h) the method of failure analysis employed and the documented results.

5.6.1.3 Safety circuits based on programmable electronic systems

In addition to 5.6.1.1 the following documentation shall be provided:

- a) documents and descriptions relating to the measures listed in Annex B;
- b) general description of the software used (e.g. programming rules, language, compiler, modules);
- c) function description including software architecture and hardware/software interaction;
- d) description of blocks, modules, data, variables and interfaces;
- e) software listings.

5.6.2 Test samples

There shall be submitted to the laboratory:

- a) one printed circuit board;
- b) one printed circuit board bare (without components).

5.6.3 Tests

5.6.3.1 Mechanical tests

5.6.3.1.1 General

During the tests, the tested object (printed circuit) shall be kept under operation. During and after the tests, no unsafe operation and condition shall appear within the safety circuit.

5.6.3.1.2 Vibration

Transmitter elements of safety circuits shall withstand the requirements of:

- a) EN 60068-2-6:2008, Endurance by sweeping: Table C.2:

20 sweep cycles in each axis, at amplitude 0,35 mm, and in the frequency range 10-55 Hz;

and also to:

- b) EN 60068-2-27:2009, Acceleration and duration of pulse: Table 1:

the combination of:

- peak acceleration 294 m/s² or 30 g_n ;
- corresponding duration of pulse 11 ms; and
- corresponding velocity change 2,1 m/s half sine.

NOTE Where shock absorbers for transmitter elements are fitted, they are considered as part of the transmitter elements.

After tests, clearances and creepage distances shall not become smaller than the minimum accepted.

5.6.3.1.3 Bumping (EN 60068-2-27:2009)

5.6.3.1.3.1 General

Bumping tests shall simulate the cases when printed circuits fall, introducing the risk of rupture of components and unsafe situation.

Tests are divided into:

- a) Partial shockings;
- b) Continuous shockings.

The tests object shall satisfy the following minimum requirements:

5.6.3.1.3.2 Partial shocking

- a) shocking shapes: half-sinus;
- b) amplitude of acceleration: 15 g;
- c) duration of shock: 11 ms.

5.6.3.1.3.3 Continuous shocking

- a) Amplitude of acceleration: 10 g;
- b) Duration of shock: 16 ms;
- c)
 - 1) Number of shocks: 1000 ± 10 ;
 - 2) Shock frequency: 2/s.

5.6.3.2 Temperature tests (EN 60068-2-14:2009)

Operating ambient limits: 0 °C, + 65 °C (the ambient temperature is of the safety device).

Test conditions:

- the printed circuit board shall be in operational position;
- the printed circuit board shall be supplied with rated operational voltage;
- the safety device shall operate during, and after the test. If the printed circuits board includes components other than safety circuits, they also shall operate during the test (their failure is not considered);
- tests shall be carried out for minimum and maximum temperature (0 °C + 65 °C). Tests shall last a minimum of four hours;
- if the printed circuit board is designed to operate within wider temperature limits, it shall be tested for these values.

5.6.3.3 Failure analysis of electric safety circuits

The failure analysis document as required by the relevant standard calling for the use of this standard shall be validated. (e.g. EN 81-20:2020, 5.11.2.3).

5.6.3.4 Functional and safety test of PESSRAL

In addition to the verification of the measures defined in Annex B, Tables B.1 to B.6, the following shall be validated:

- a) Software design and coding: Inspect all code statements using methods such as formal design reviews, FAGAN, test cases etc.;
- b) Software and hardware inspection: Verify all measures of Annex B, Tables B.1 and B.2 and the measures chosen e.g. from Table B.7 by using for example fault insertion testing (based on EN 61508-2:2010 and EN 61508-7:2010).

5.6.4 Type examination certificate

The certificate shall indicate:

- a) information according to Annex A;
- b) type and application of the circuitry;

- c) design for pollution degree according to EN 60664-1:2007;
- d) operating voltages;
- e) distances between the safety circuits and the rest of the control circuits on the board.

NOTE Other tests like humidity test, climatic shock test, etc. are not subject for tests because of the normal environmental situation where lifts are operating.

5.7 Type examination of ascending car overspeed protection means

5.7.1 General provisions

5.7.1.1 This specification applies to ascending car overspeed protection means which are not using overspeed governors, or programmable electronic systems which are subject to verifications according to 5.4 and 5.6. Test results of safety gears which have been verified according to 5.3 may be taken into account for verification of permissible application range.

5.7.1.2 The applicant shall state the range of use provided:

- a) minimum and maximum masses, or torque;
- b) minimum (if applicable) and maximum rated speed;
- c) use in installations with compensating ropes.

5.7.1.3 The following documents shall be attached to the applications:

- a) detailed and assembly drawings showing the construction, operation, materials used, the dimensions and tolerances on the construction components;
- b) if necessary, also a load diagram relating to elastic parts;
- c) detailed information on the materials used, the type of part on which the ascending car overspeed protection means acts, and its surface condition (drawn, milled, ground, etc.).

5.7.2 Statement and test sample

5.7.2.1 The applicant shall state for what mass (in kilograms) and tripping speed (in meters per second) the test will be carried out. If the device shall be certified for various masses, the applicant shall specify them and indicate in addition whether adjustment is by stages or continuous.

5.7.2.2 As defined between applicant and the laboratory:

- either a complete assembly consisting of both elements, braking device and speed monitoring device; or
- only that device which was not subject to verifications according to 5.3, 5.4 and 5.6;

shall be provided by the applicant.

The number of sets of gripping elements necessary for all the tests shall be attached. The type of part on which the device acts, shall also be supplied with the dimensions agreed with the laboratory.

5.7.3 Test

5.7.3.1 Method of test

The method of test shall be defined between applicant and test laboratory, depending on the device and its functioning to achieve a realistic function of the system. Measurements shall be made of:

- a) the acceleration and speed;
- b) the braking distance;
- c) the retardation.

Measurements shall be recorded as a function of the time.

5.7.3.2 Test procedure

5.7.3.2.1 General

At least twenty tests shall be made with the speed monitoring element in the speed range for tripping corresponding to the range of rated speeds of the lift indicated in 5.7.1.2.

The acceleration of the mass to reach the tripping speed should be as low as possible, in order to eliminate the effects of inertia.

5.7.3.2.2 Device certified for a single mass

The laboratory shall carry out four tests with the system mass representing an empty car.

Between each test the friction parts shall be allowed to return to their normal temperature.

During the tests several identical sets of friction parts may be used.

However, one set of parts shall be capable of:

- a) three tests, if the rated speed does not exceed 4 m/s;
- b) two tests, if the rated speed exceeds 4 m/s.

The test shall be made at the maximum tripping speed for which the device may be used.

5.7.3.2.3 Device certified for different masses

Adjustment in stages or continuous adjustment.

A series of tests shall be carried out for the maximum value applied for and a series for the minimum value. The applicant shall supply a formula, or a chart, showing the variation of the braking force as a function of a given parameter.

The laboratory shall verify by suitable means (in the absence of anything better, by a third series of tests for intermediary points) the validity of the supplied formula.

5.7.3.2.4 Overspeed monitoring device

5.7.3.2.4.1 Test procedure

At least twenty tests shall be made in the speed range for tripping without applying the braking device.

The majority of tests shall be made at the extreme values of the range.

5.7.3.2.4.2 Interpretation of the test results

In the course of twenty tests the tripping speeds shall lie within the limits called for in the standards calling for the use of this standard (e.g. EN 81-20:2020, 5.6.6.1).

5.7.3.3 Checking after the tests

After the test:

- a) the hardness of the gripping element shall be compared with the original values quoted by the applicant;
- b) if there is no fracture, deformations and other changes shall be examined (for example, cracks, deformations or wear of the gripping elements, appearance of the rubbing surfaces);
- c) if necessary, photographs shall be taken of the gripping elements and the parts on which the device acts for evidence of deformations or fractures;
- d) it shall be checked that the retardation with the minimum mass has not exceeded $1 g_n$.

5.7.4 Possible modification to the adjustments

If, during the tests, the values found differ by more than 20 % from those expected by the applicant, other tests may be made with his agreement, after modification of the adjustments if necessary.

5.7.5 Test report

In order to achieve reproducibility the type examination shall be recorded in all details, such as:

- the method of test defined between applicant and laboratory;
- the description of the testing arrangement;
- location of the device to be tested in the testing arrangement;
- number of tests carried out;
- record of measured values;
- report of observations during the test;
- evaluation of the test results to show compliance with the requirements.

5.7.6 Type examination certificate

The certificate shall indicate:

- a) information according to Annex A;
- b) type and application of overspeed protection means;
- c) the limits of the permissible masses;
- d) the tripping speed range of the overspeed monitoring device;
- e) the type of parts on which the braking elements act.

5.8 Type examination of unintended car movement protection means

5.8.1 General provisions

The unintended car movement protection means shall be type tested as a complete system or the subsystems for detection, activation and stopping may be submitted to an individual type examination. The type examination of subsystems shall define interface conditions and the relevant parameters of each subsystem if integrated in a complete system.

The applicant shall state the key parameters for use of the system or subsystem that form part of the type examination:

- minimum and maximum masses;
- minimum and maximum force or torque or fluid pressure, if applicable;
- individual response times of detector, control circuit and stopping element(s);
- highest speed anticipated before deceleration occurs (see Note 1);
- distance from the floor at which the detector device will be installed;
- test speed(s) (see Note 2);
- limits of temperature and humidity of the design and any other relevant information agreed between the applicant and test laboratory.

NOTE 1 As an example and indication, for traction lifts, where the natural acceleration is $1,5 \text{ m/s}^2$ and without any torque contribution from the motor, the maximum speed attainable would be in the magnitude of 2 m/s . This is based on the speed attained at start of deceleration e.g. being the result of a “natural” acceleration of $1,5 \text{ m/s}^2$ through the response times of the unintended car movement protection device, control circuit and stopping elements, assuming that the movement detector operates when the car reaches the limit of the unlocking zone.

In case of electric failure it can be assumed for traction lifts due to internal control means the acceleration which can be achieved is not greater than $2,5 \text{ m/s}^2$.

NOTE 2 Test speed(s): a speed stated by the manufacturer, used by the test laboratory to establish a distance moved by the lift (verification distance) so that the unintended movement system is verified for correct operation during examinations and tests before putting into service at site. This could be the inspection speed or any other speed determined by the manufacturer and agreed by the laboratory.

The distance the car is permitted to move during unintended movement is defined in the requirements laid down in the standards calling for the use of this standard (e.g. EN 81-20:2020, 5.6.7.5).

The following documents shall be attached to the application:

- a) Detailed and assembly drawings showing the construction, operation, the dimensions and tolerances of the components;
- b) If necessary, also a load diagram relating to elastic parts;
- c) Detailed information of the materials used, the type of part on which the means acts, and its surface condition, if relevant (drawn, milled, ground, etc.).

5.8.2 Statement and test sample

5.8.2.1 The applicant shall state for what duty the means is intended.

5.8.2.2 Test samples shall be supplied as agreed between applicant and the laboratory consisting of, as appropriate, a complete assembly of unintended car movement detection device, control circuit (actuator), stopping elements and any monitoring device(s) if applicable.

The number of sets of gripping elements necessary for all the tests shall be attached.

The type of part on which the device acts, shall also be supplied with the dimensions specified by the laboratory.

5.8.3 Test

5.8.3.1 Method of Test

The method of test shall be defined between applicant and test laboratory, depending on the device and its function to achieve a realistic operation of the system.

Measurements shall be made of:

- the stopping distance;
- the average retardation;
- the response time of the detection, actuation, stopping element and control circuits (see Figure 2);
- the total distance travelled (sum of acceleration and stopping distances).

Test shall also include:

- operation of the unintended car movement detection device and
- any automatic monitoring system, if applicable.

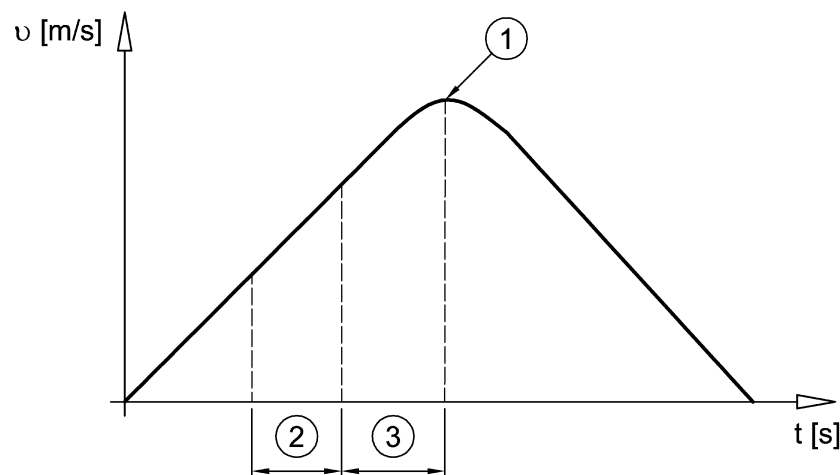

Key

- ① point at which stopping elements start to cause a reduction in speed
- ② response time of unintended car movement detection and any control circuits
- ③ response time of actuation circuits and stopping elements

Figure 2 — Response times

5.8.3.2 Test procedure

5.8.3.2.1 General

Twenty tests shall be made on the stopping element with:

- no result outside the specification,
- each result within $\pm 20\%$ of the average value.

Average value shall be stated on the certificate.

5.8.3.2.2 Device certified for a single mass or torque or fluid pressure

The laboratory shall carry out 10 tests with the system mass or torque or fluid pressure representing an empty car in up direction and 10 tests with the system mass or torque or fluid pressure representing a car carrying the rated load in down direction.

Between each test the friction parts shall be allowed to return to their normal temperature.

During the tests several identical sets of friction parts may be used. However, one set of parts shall be capable of 5 tests minimum.

5.8.3.2.3 Device certified for different masses or torques or fluid pressures

A series of tests shall be carried out for the maximum value applied for and a series for the minimum value.

The applicant shall supply a formula or a chart, showing the calculated variation of the braking force or torque or fluid pressure as a function of a given adjustment. The results being expressed in distance travelled.

The laboratory shall verify the validity of the formula or chart.

5.8.3.2.4 Test procedure for unintended movement detection means

10 tests shall be made to verify the operation of the device. All tests shall be positive to verify correct operation.

5.8.3.2.5 Test procedure for self-monitoring

10 tests shall be made to verify the operation of the device. All tests shall be positive to verify correct operation.

In addition the capability of the self-monitoring to detect loss of redundancy of the stopping element before a critical situation occurs shall be verified.

5.8.3.3 Checks after the test

After the test:

- a) The mechanical characteristics of the stopping element(s) shall be compared with the original values quoted by the applicant. Other analyses may be carried out in special cases;
- b) It shall be checked that there are no fractures or deformations or any other changes (e.g. cracks, deformations or wear of the gripping elements, appearance of the rubbing surfaces);
- c) If necessary, photographs shall be taken of the gripping elements and the parts on which the device acts for evidence of deformations or fractures.

5.8.4 Possible modification to the adjustments

If, during the tests, the values found differ by more than 20 % from those expected by the applicant, another series of tests may be made with his agreement, after modification of the adjustments if necessary.

5.8.5 Test report

In order to achieve reproducibility, the type examination shall be recorded in all details, such as:

- the method of test defined between applicant and laboratory;
- the description of the testing arrangement;
- location of the device to be used when installed in the testing arrangement;
- number of tests carried out;
- record of all measured values;
- report of observations during the test;
- evaluation of the test results to show compliance with the requirements.

5.8.6 Type examination certificate

The certificate shall indicate:

- a) information according to Annex A;
- b) type and application of the unintended car movement protection system/subsystem;
- c) the limits of the key parameters (as agreed between laboratory and manufacturer);
- d) the test-speed with relevant parameters for final inspection use;
- e) the type of parts on which the stopping elements act;
- f) the combination of “detecting” device and “stopping” element of the means in the case of complete systems;
- g) interface conditions in case of subsystems.

5.9 Type examination of rupture valve/one-way restrictor

NOTE In the following the term “rupture valve” means “rupture valve/one-way restrictor with mechanical moving parts”.

5.9.1 General provisions

5.9.1.1 General

The applicant shall state:

- a) The range of:
 - 1) flow;

- 2) pressure;
 - 3) viscosity;
 - 4) ambient temperature;
- b) The method of mounting;

of the rupture valve to be type examined.

Details and assembly drawings showing the construction, operation, adjustment, materials, dimensions and tolerances of the rupture valve and the construction components shall be attached to the application.

5.9.1.2 Samples to be submitted

There shall be submitted to the laboratory:

- a) one rupture valve;
- b) a list of liquids which may be used together with the rupture valve or a sufficient amount of special liquid to be used;
- c) if necessary adaptation means to the test facilities of the laboratory.

5.9.1.3 Test

5.9.1.3.1 Test installation

The rupture valve, mounted in its intended method, shall be tested in a hydraulic system, where:

- a) the required testing pressure is dependent from a mass;
- b) the flow is controlled by adjustable valves;
- c) the pressure before ²⁾ and behind the rupture valve can be recorded;
- d) installations to vary the ambient temperature of the rupture valve and the viscosity of the hydraulic liquid are provided.

The system shall allow to record the flow over the time. To determine the values of flow, the measurement of another figure, i.e. the speed of the ram, from which the flow can be derived, is permitted.

5.9.1.3.2 Measuring instruments

The measuring instruments shall have accuracy according to 5.1.2.6.

5.9.1.4 Test procedure

5.9.1.4.1 General

The test shall:

- a) simulate a total piping failure occurring at a moment when the speed of the car is zero;

2) "Before the rupture valve" means between the cylinder and the rupture valve.

b) evaluate the resistance of the rupture valve against pressure.

5.9.1.4.2 Simulation of a total piping failure

5.9.1.4.2.1 Simulating a total piping failure, the flow shall be initiated from a static situation by opening a valve under the condition that the static pressure before the rupture valve decrease to less than 10 %.

The tolerances of the closing valve shall be taken into account within the stated range of:

- a) flow;
- b) viscosity;
- c) pressure;
- d) ambient temperature.

That can be achieved by 2 test series with:

- maximum pressure, maximum ambient temperature, minimum adjustable flow and minimum viscosity;
- minimum pressure, minimum ambient temperature, maximum adjustable flow and maximum viscosity.

In each test series at least 10 tests shall be carried out, to evaluate the tolerances of operation of the rupture valve under these conditions.

5.9.1.4.2.2 During the tests the relation between:

- flow and time, and;
- pressure before the rupture valve and time;
- pressure behind the rupture valve and time,

shall be recorded.

The typical characteristics of these curves are shown in the Figure 3.

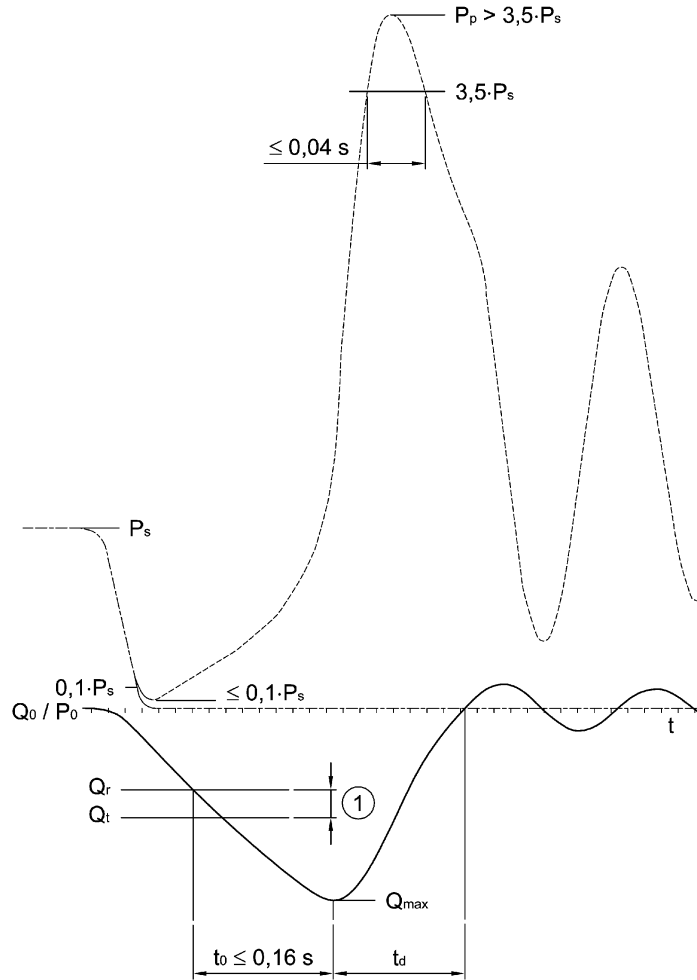

Key

- P_0 pressure before test
- P_p pressure peak
- P_s pressure static
- Q_0 flow before test
- Q_{max} maximum flow
- Q_r flow at rated speed detection point
- Q_t flow at tripping point
- t time
- t_o time between detection point and maximum flow before closing
- t_d time between maximum closing flow and zero flow before any rebound
- . — . pressure after rupture valve
- hydraulic fluid flow
- — — pressure before rupture valve
- ① the rupture valve shall be tripped before the speed is equal to rated speed + 0,3 m/s

Figure 3 — Hydraulic fluid flow through, pressure before and behind the rupture valve

5.9.1.4.3 Resistance against pressure

Showing the resistance of the rupture valve against pressure it shall be submitted to a pressure test with 5 times the maximum pressure over 2 min.

5.9.1.5 Interpretation of the tests

5.9.1.5.1 Closing operation

The rupture valve fulfils the requirements of the standard if the curves recorded according to 5.9.1.4.2 show that:

a) The time t_o between rated flow (100 % flow) and the maximum flow Q_{max} does not exceed 0,16 s;

b) The time t_d for the decrease of flow is: $\frac{|Q_{max}|}{6 \cdot A \cdot 9,81} \leq t_d \leq \frac{|Q_{max}|}{6 \cdot A \cdot 1,96}$

where:

A is the area of jack, where pressure is acting in square centimetres;

Q_{max} is the maximum flow of the hydraulic fluid in litre per minute;

t_d is the braking time in seconds;

c) Pressure of more than $3,5 \cdot P_s$ shall not last longer than 0,04 s;

where

P_s is the static pressure;

d) The rupture valve shall be tripped before the speed is equal to rated speed + 0,30 m/s.

5.9.1.5.2 Pressure resistance

The rupture valve fulfils the requirements of the standard if after the pressure test according to 5.9.1.4.3 it shows no permanent damage.

5.9.1.5.3 Readjustment

If the limits of flow decrease or pressure peaks are exceeded, the manufacturer may modify the adjustment of the rupture valve. After that another test series shall be carried out.

5.9.1.6 Type examination certificate

The certificate shall indicate:

a) Information according to Annex A;

b) Type and application of the rupture valve;

c) The range of

1) flow of the rupture valve;

2) pressure of the rupture valve;

3) viscosity of hydraulic fluids to be used;

- 4) ambient temperature of the rupture valve.

The certificate shall be accompanied with a graph according to Figure 3 showing the relationship between flow of hydraulic fluid and pressure from which Q_{max} and t_d can be obtained.

5.10 Guide rails calculation

5.10.1 Range of calculation

Guide rails shall be dimensioned taking into account the following stresses:

- bending stress;
- combined bending;
- buckling stress;
- compression stress/tension stress;
- combined bending and compression/tension stress;
- combined buckling and bending;
- flange bending stress.

In addition deflections shall be analysed.

NOTE An example for a calculation based on the following method is given in Annex C.

5.10.2 Bending

5.10.2.1 Calculating the bending stresses in the different axis of the guide rail (Figure 4), it can be assumed that:

- the guide rail is a continuous beam with flexible fixing points at distances of the length l ;
- the resultant of forces causing bending stresses act in the middle between adjacent fixing points;
- bending moments act on the neutral axis of the profile of the guide rail.

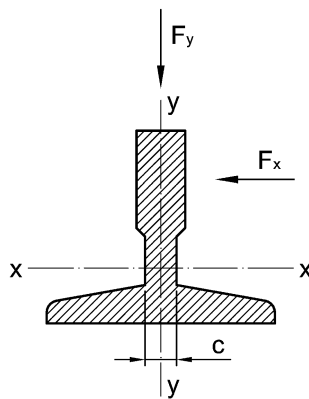

Figure 4 — Axis of the guide rail

Evaluating the bending stress - σ_m - from horizontal forces acting at right angles to the axis of the profile, the following formulae shall be used: $\sigma_m = \frac{M_m}{W}$ with $M_m = \frac{3 \cdot F_h \cdot l}{16}$

where:

F_h is the horizontal force applied to the guide rail by the guide shoes in the different load cases in newtons;

l is the maximum distance between guide brackets in millimetres;

M_m is the bending moment in newtons millimetres;

σ_m is the bending stress in newtons per square millimetre;

W is the cross sectional area modulus in cubic millimetres.

5.10.2.2 Bending stresses in different axes shall be combined taking into account the guide rail profile.

If for W_x and W_y the usual values of tables (respectively W_{xmin} and W_{ymin}) are used and therewith the permissible stresses are not exceeded, no further proof is necessary. Otherwise it shall be analysed at which outer edge of the guide rail profile the tensile stresses have their maximum.

5.10.2.3 If more than two guide rails are used, an equal distribution of the forces between the guide rails may be assumed, provided their profiles are identical.

5.10.2.4 If more than one safety gear is used, acting on different guide rails, it can be assumed that the whole braking force is equally distributed between the safety gears.

5.10.2.5 In the case of vertical multiplex safety gears acting on the same guide rail, it shall be assumed, that the braking force of a guide rail is acting on one point.

5.10.3 Buckling

Determining the buckling stresses the "omega" method shall be used with the following formulae:

$$\sigma_k = \frac{(F_v + k_3 \cdot M_{aux}) \cdot \omega}{A}$$

where:

A is the cross sectional area of a guide rail in square millimetres;

F_v is the vertical force on a guide rail of the car, counterweight or balancing weight in newtons;

k_3 is the impact factor;

M_{aux} is the force in a guide rail due to auxiliary equipment in newtons;

σ_k is the buckling stress in newtons per square millimetre;

ω is the omega value.

The "omega"-values can be evaluated by using the following polynomials with: $\lambda = \frac{l_k}{i}$ and $l_k = l$

where:

$\lambda = \frac{l_k}{i}$ is the slenderness;

i is the minimum radius of gyration in millimetres;

l is the maximum distance between guide brackets in millimetres;

l_k is the buckling length in millimetres.

For steel with tensile strength $R_m = 370 \text{ N/mm}^2$:

$$20 \leq \lambda \leq 60 : \quad \omega = 0,00012920 \cdot \lambda^{1,89} + 1 ;$$

$$60 < \lambda \leq 85 : \quad \omega = 0,00004627 \cdot \lambda^{2,14} + 1 ;$$

$$85 < \lambda \leq 115 : \quad \omega = 0,00001711 \cdot \lambda^{2,35} + 1,04 ;$$

$$115 < \lambda \leq 250 : \quad \omega = 0,00016887 \cdot \lambda^{2,00}$$

For steel with tensile strength $R_m = 520 \text{ N/mm}^2$:

$$20 \leq \lambda \leq 50 : \quad \omega = 0,00008240 \cdot \lambda^{2,06} + 1,021 ;$$

$$50 < \lambda \leq 70 : \quad \omega = 0,00001895 \cdot \lambda^{2,41} + 1,05 ;$$

$$70 < \lambda \leq 89 : \quad \omega = 0,00002447 \cdot \lambda^{2,36} + 1,03 ;$$

$$89 < \lambda \leq 250 : \quad \omega = 0,00025330 \cdot \lambda^{2,00} .$$

The determination of "omega"-values of steel with tensile strength R_m between 370 N/mm^2 and 520 N/mm^2 shall be carried out by using the following formula:

$$\omega_R = \left[\frac{\omega_{520} - \omega_{370}}{520 - 370} \cdot (R_m - 370) \right] + \omega_{370}$$

5.10.4 Combination of bending and compression/tension or buckling stresses

The combined bending and compression/tension or buckling stresses shall be evaluated using the following formulae:

Bending stresses $\sigma = \sigma_m = \sigma_x + \sigma_y \leq \sigma_{perm}$

Bending and compression/tension $\sigma = \sigma_m + \frac{F_v + k_3 \cdot M_{aux}}{A} \leq \sigma_{perm}$

Bending and buckling $\sigma = \sigma_k + 0,9 \cdot \sigma_m \leq \sigma_{perm}$

where:

- A is the cross sectional area of a guide rail in square millimetre;
- F_v is the vertical force on a guide rail of the car, counterweight or balancing weight in newtons;
- k_3 is the impact factor;
- M_{aux} is the force in a guide rail due to auxiliary equipment in newtons;
- σ is the combined stress in newtons per square millimetre;
- σ_k is the buckling stress in newtons per square millimetre
- σ_m is the bending stress in newtons per square millimetre;
- σ_{perm} is the permissible stress in newtons per square millimetre, see the standards calling for the use of this standard (e.g. EN 81-20:2020, 5.7.4.5);
- σ_x is the bending stress in the x-axis in newtons per square millimetre;
- σ_y is the bending stress in the y-axis in newtons per square millimetre.

5.10.5 Flange bending

Flange bending shall be taken into consideration. For T-shaped guide rails, the following formulae shall be used:

$$\sigma_F = \frac{1,85 \cdot F_x}{c^2} \leq \sigma_{perm} \quad \text{for roller guide shoes}$$

$$\sigma_F = \frac{F_x \cdot (h_1 - b - f) \cdot 6}{c^2 \cdot (l + 2 \cdot (h_1 - f))} \leq \sigma_{perm} \quad \text{for sliding guide shoes}$$

where:

- b is half the width of the guide shoe lining in millimetres;
- c is the width of the connecting part of the foot to the blade in millimetres;
- f is the foot depth of guide rail at its connection with the blade in millimetres;
- F_x is the force exerted by a guide shoe to the flange in newtons;
- h_1 is the guide rail height in millimetres;
- l is the length of the guide shoe lining in millimetres;
- σ_F is the local flange bending stress in newtons per square millimetre;
- σ_{perm} is the permissible stress in newtons per square millimetre.

NOTE Dimensions are shown in Figure 5.

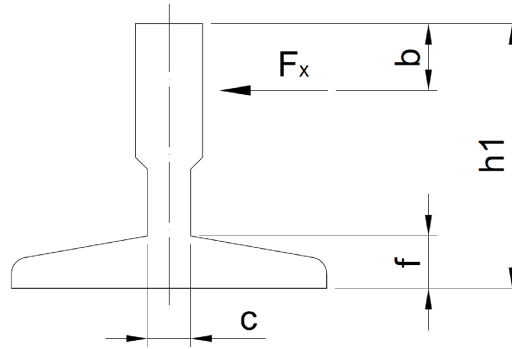

Figure 5 — Dimensions for flange bending calculation

5.10.6 Deflections

The deflections shall be calculated by using the following formulae:

$$\delta_y = 0,7 \frac{F_y \cdot l^3}{48 \cdot E \cdot I_x} + \delta_{str-y} \leq \delta_{perm}$$

$$\delta_x = 0,7 \frac{F_x \cdot l^3}{48 \cdot E \cdot I_y} + \delta_{str-x} \leq \delta_{perm}$$

where:

- δ_{perm} is the maximum permissible deflection in millimetres;
- δ_x is the deflection in the X-axis in millimetres;
- δ_y is the deflection in the Y-axis in millimetres;
- δ_{str-x} is the deflection of the building structure in the x-axis in millimetres;
- δ_{str-y} is the deflection of the building structure in the y-axis in millimetres;
- E is the modulus of elasticity in newtons per square millimetre;
- F_x is the supporting force in the X-axis in newtons;
- F_y is the supporting force in the Y-axis in newtons;
- I_x is the second moment of area in the X-axis in fourth power millimetres;
- I_y is the second moment of area in the Y-axis in fourth power millimetres;
- l is the maximum distance between guide brackets in millimetres.

5.11 Evaluation of traction

5.11.1 Introduction

Traction shall be ensured at all times taking into account:

- normal travel;
- loading the car at floor level; and
- retardation due to an emergency stop.

If the lift machine torque is sufficiently high to raise the car, considerations shall be given to allow slip to occur if the car or the counterweight is stalled in the well for any reason.

The following dimensioning procedure applies for the evaluation of traction in the traditional applications which include steel wire ropes and steel/cast iron sheaves.

NOTE The results are, as shown by experience, safe due to built-in safety margins. Therefore the following elements need not to be taken into consideration in detail: Rope construction, type and amount of lubrication, material of sheaves and ropes and manufacturing tolerances.

5.11.2 Traction calculation

5.11.2.1 General

The following formulae shall be applied:

$$\frac{T_1}{T_2} \leq e^{f\alpha} \quad \text{for car loading and emergency braking conditions;}$$

$$\frac{T_1}{T_2} \geq e^{f\alpha} \quad \text{for car/counterweight stalled conditions (car/counterweight resting on the buffers and the machine rotating in the "down/up" direction) where protection against raising of the car or counterweight is provided by limiting of traction:}$$

where:

α is the angle of wrap of the ropes on the traction sheave;

f is the friction factor;

T_1 , T_2 are the forces in the portion of the ropes situated at either side of the traction sheave.

5.11.2.2 Evaluation of T_1 and T_2

5.11.2.2.1 Car loading condition

The static ratio T_1/T_2 shall be evaluated for the worst case depending on the position of the car in the well with 125 % of the rated load.

Where handling devices, which are not included in the rated load, are used to load/unload the car the weight of such devices shall be added to the rated load for the purpose of this calculation.

5.11.2.2.2 Emergency braking condition

The dynamic ratio T_1/T_2 shall be evaluated for the worst case depending on the position of the car in the well and the load conditions (empty, or with rated load).

Each moving element shall be considered with its proper rate of retardation, taking into account the reeving ratio of the installation.

In no case shall the rate of retardation to consider be less than:

- in normal case 0,5 m/s²;
- in case of reduced buffer stroke the minimum retardation to slow down the car and counterweight to a value not exceeding that for which the buffers are designed.

5.11.2.2.3 Car/counterweight stalled condition

The static ratio T_1/T_2 shall be evaluated for the empty car at the highest and lowest position.

5.11.2.3 Evaluation of the friction factor

5.11.2.3.1 Grooving considerations

5.11.2.3.1.1 Semi-circular and semi-circular undercut grooves

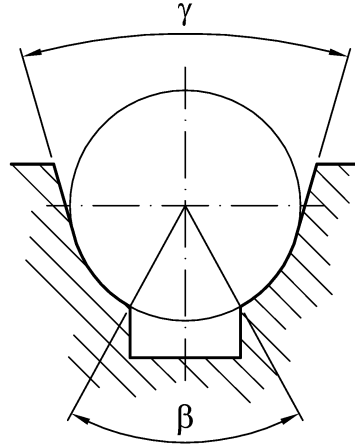

Key

- β undercut angle
- γ groove angle

Figure 6 — Semi-circular groove, undercut

The following formula shall be used: $f = \mu \cdot \frac{4 \left(\cos \frac{\gamma}{2} - \sin \frac{\beta}{2} \right)}{\pi - \beta - \gamma - \sin \beta + \sin \gamma}$

where:

- β is the value of the undercut angle;
- γ is the value of the groove angle;
- μ is the friction coefficient;
- f is the friction factor.

The maximum value of the undercut angle β shall not exceed 105° (1,83 rad).

The value of the groove angle γ shall be given by the manufacturer according to the grooving design. In no case it should be less than 25° (0,44 rad).

5.11.2.3.1.2 V-grooves

Where the groove has not been submitted to an additional hardening process, in order to limit the deterioration of traction due to wear, an undercut is necessary.

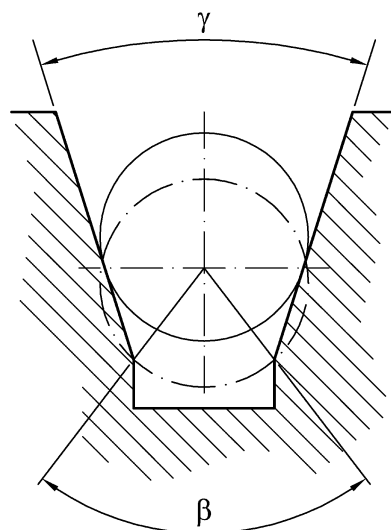

Key

- β undercut angle
- γ groove angle

Figure 7 — V-groove

The following formulae apply:

- in the case of car loading and emergency braking:

$$f = \mu \cdot \frac{4 \left(1 - \sin \frac{\beta}{2} \right)}{\pi - \beta - \sin \beta} \quad \text{for non-hardened grooves;}$$

$$f = \mu \cdot \frac{1}{\sin \frac{\gamma}{2}} \quad \text{for hardened grooves;}$$

- in the case of counterweight stalled conditions:

$$f = \mu \cdot \frac{1}{\sin \frac{\gamma}{2}} \quad \text{for hardened and non-hardened grooves}$$

where:

- β is the value of the undercut angle;
- γ is the value of the groove angle;
- μ is the friction coefficient;
- f is the friction factor.

The maximum value of the undercut angle β shall not exceed 105° (1,83 rad). In no case, angle γ shall be less than 35° for lifts.

5.11.2.3.2 Friction coefficient consideration

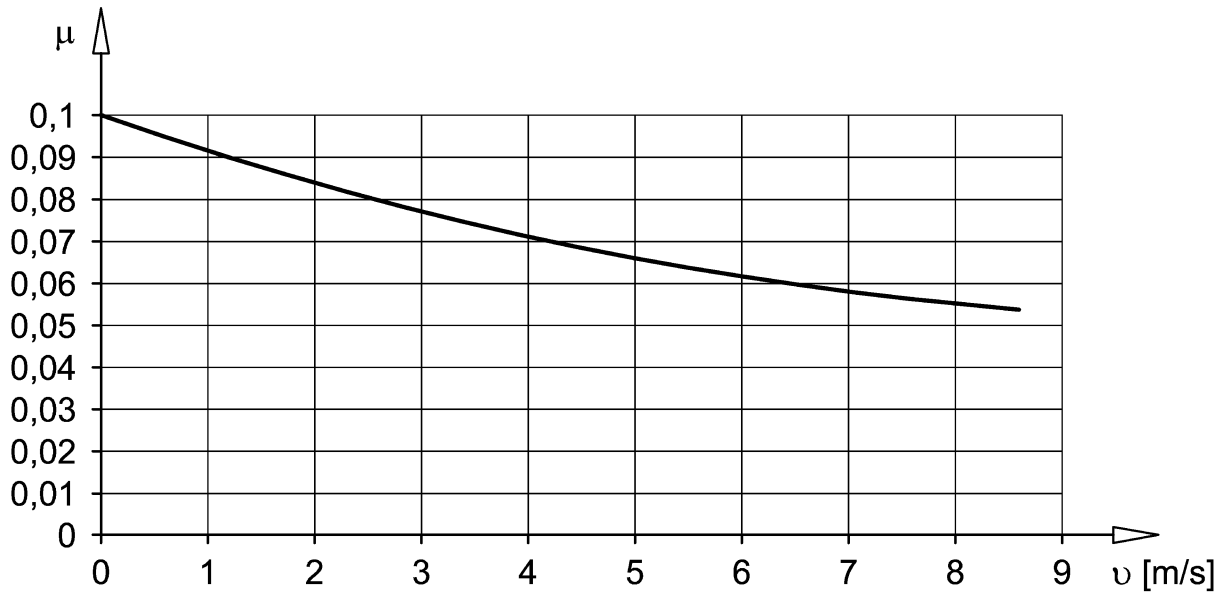

Figure 8 — Minimum friction coefficient

The following values apply:

- Loading conditions $\mu = 0,1$;
- Emergency braking conditions $\mu = \frac{0,1}{1 + \frac{v}{10}}$;
- Counterweight stalled conditions $\mu = 0,2$

where:

- μ is the friction coefficient;
- v is the rope speed at rated speed of the car.

5.11.3 Formulae for a general case

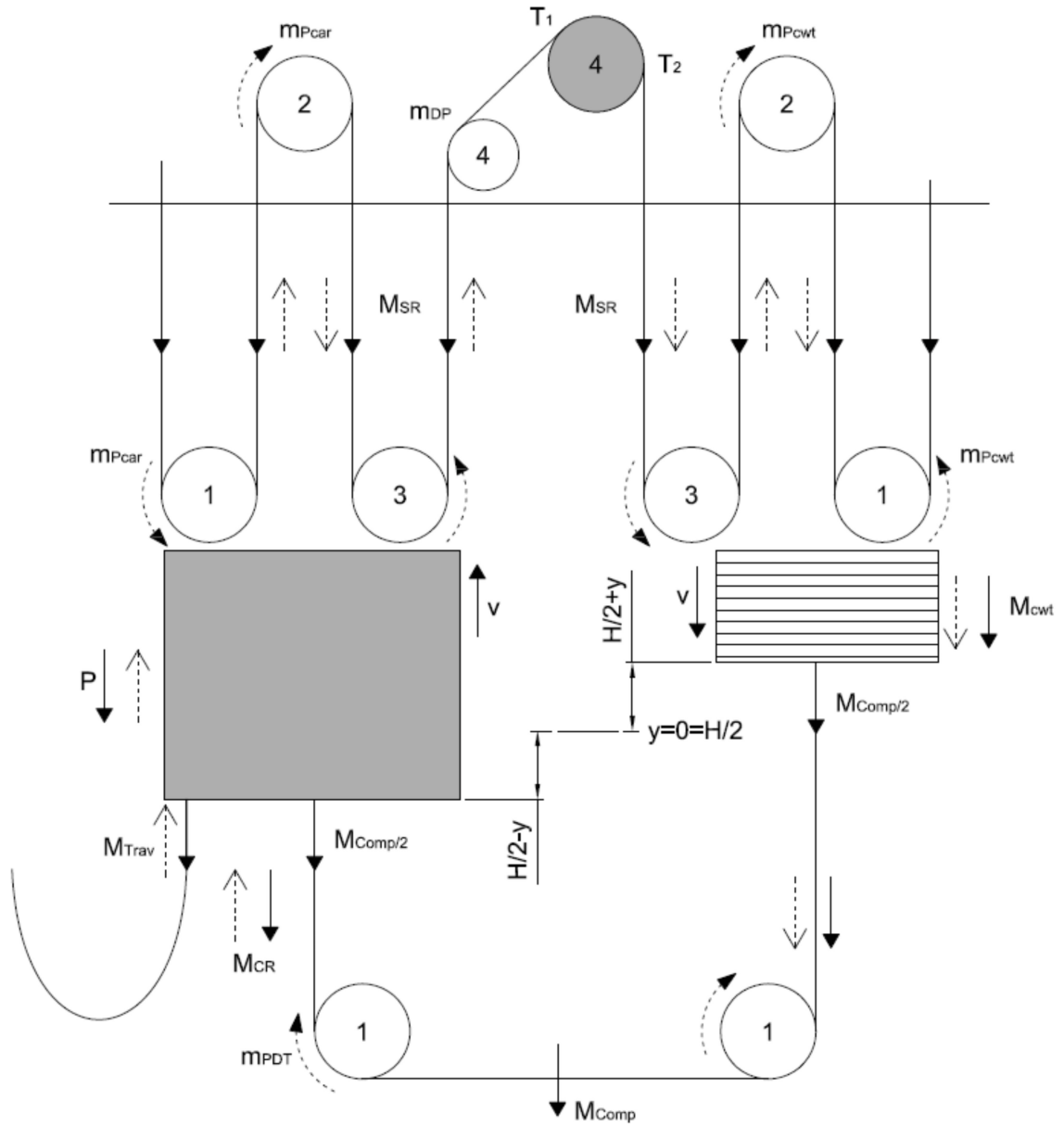

Key

1, 2, 3, 4 is the speed factor of pulleys (example: $2 = 2 \cdot v_{car}$).

Figure 9 — General case

The following formulae apply:

a) For machinery located above:

$$T_1 = \frac{(P + Q + M_{CRcar} + M_{Trav})}{r} \cdot (g_n \pm a) + \frac{M_{Comp}}{2 \cdot r} \cdot g_n + M_{SRcar} \left(g_n \pm a \cdot \frac{r^2 + 2}{3} \right) \pm \left(\frac{i_{PTD} \cdot m_{PTD}}{2 \cdot r} \cdot a \right) \\ \pm \frac{(m_{DP} \cdot a)^I}{r} \pm \left[\frac{\sum_{i=1}^{r-1} (m_{Pcar} \cdot i_{Pcar} \cdot a)}{r} \right]^{III} \mp \frac{FR_{car}}{r}$$

$$T_2 = \frac{M_{cwt} + M_{CRcwt}}{r} \cdot (g_n \mp a) + \frac{M_{Comp}}{2 \cdot r} \cdot g_n + M_{SRcwt} \left(g_n \mp a \cdot \frac{r^2 + 2}{3} \right) \mp \left(\frac{i_{PTD} \cdot m_{PTD}}{2 \cdot r} \cdot a \right) \\ \mp \left[\frac{(m_{DP} \cdot a)^{II}}{r} \right] \mp \left[\frac{\sum_{i=1}^{r-1} (M_{Pcwt} \cdot i_{Pcwt} \cdot a)}{r} \right]^{III} \pm \frac{FR_{cwt}}{r}$$

b) For machinery located below:

$$T_1 = \frac{(P + Q + M_{CRcar} + M_{Trav})}{r} \cdot (g_n \pm a) + \frac{M_{Comp}}{2 \cdot r} \cdot g_n + M_{SR1car} \cdot (-g_n \pm a) + M_{SR2car} \cdot \left(g_n \pm a \cdot \frac{r^2 + 2}{3} \right) \\ \pm \left(\frac{i_{PTD} \cdot m_{PTD}}{2 \cdot r} \cdot a \right) \pm \left(\frac{m_{DP} \cdot a}{r} \right)^I \pm \left[\frac{\sum_{i=1}^{r-1} (m_{Pcar} \cdot i_{Pcar} \cdot a)}{r} \right]^{III} \mp \frac{FR_{car}}{r}$$

$$T_2 = \frac{M_{cwt} + M_{CRcwt}}{r} \cdot (g_n \mp a) + \frac{M_{Comp}}{2 \cdot r} \cdot g_n + M_{SR1cwt} \cdot (-g_n \mp a) + M_{SR2cwt} \cdot \left(g_n \mp a \cdot \frac{r^2 + 2}{3} \right) \\ \mp \left(\frac{i_{PTD} \cdot m_{PTD}}{2 \cdot r} \cdot a \right) \mp \left(\frac{m_{DP} \cdot a}{r} \right)^{II} \mp \left[\frac{\sum_{i=1}^{r-1} (m_{Pcwt} \cdot i_{Pcwt} \cdot a)}{r} \right]^{III} \pm \frac{FR_{cwt}}{r}$$

NOTE 1 The above formulas may be also used for the empty car by deleting Q . In this case T_1 becomes T_2 and T_2 becomes T_1 .

In the above formulas the symbols \pm and \mp shall be used in such a way that the upper operation is applicable in case the car with its rated load is retarding in the down direction and the lower operation in case the empty car is retarding in the up direction. For the cases car loading and stalled condition $a = 0$.

For the car loading case Q shall be replaced by $1,25 Q$ plus the weight of handling devices where used in case of goods passenger lifts.

The friction forces FR_{car} and FR_{cwt} should be deleted in all conditions if a minimum friction force cannot be ensured.

NOTE 2 For calculation example, see Annex D.

Conditions:

- I* is for any deflection pulley on car side;
- II* is for any deflection pulley on counterweight side;
- III* is only for reeving > 1;

where:

- a* is the braking retardation (positive value) of the car in metres per square second;
- FR_{car} is the frictional force in the well (efficiency of bearings car side and friction on guide rails, etc.) in newtons;
- FR_{cwt} is the frictional force in the well (efficiency of bearings counterweight side and friction on guide rails, etc.) in newtons;
- g_n is the standard acceleration of free fall in metres per square second;
- H* is the travel height in metres;
- i_{Pcar} is the number of pulleys on car side with same rotation speed v_{pulley} (without deflection pulleys);
- i_{Pcwt} is the number of pulleys on counterweight side with same rotation speed v_{pulley} (without deflection pulleys);
- i_{PTD} is the number of pulleys for tensioning device;
- m_{DP} is the reduced mass (related to the car/counterweight) of deflection pulleys on car and/or counterweight side $J_{DP} \cdot (v_{pulley}/v)^2 / R^2$ in kilograms;
- m_{Pcar} is the reduced mass (related to the car) of pulleys on car side $J_{Pcar} \cdot (v_{pulley}/v)^2 / R^2$ in kilograms;
- m_{Pcwt} is the reduced mass (related to the counterweight) of pulleys on counterweight side $J_{Pcwt} \cdot (v_{pulley}/v)^2 / R^2$ in kilograms;
- m_{PTD} is the reduced mass (related to car/counterweight) of one pulley on tensioning device J_{PTD} / R^2 in kilograms;
- M_{Comp} is the mass of tension device including mass of pulleys in kilograms;
- M_{CR} is the actual mass of compensation ropes/chains $([0,5 \cdot H \pm y] \cdot n_c \cdot \text{rope weight per unit length})$ in kilograms;
- M_{CRcar} is the mass M_{CR} on car side;
- M_{CRcwt} is the mass M_{CR} on counterweight side;
- M_{cwt} is the mass of counterweight including mass of pulleys in kilograms;
- M_{SR} is the actual mass of suspension ropes $([0,5 \cdot H \pm y] \cdot n_s \cdot \text{rope weight per unit length})$ in kilograms;
- M_{SRcar} is the mass M_{SR} on car side.

In the case of machine below, the rope leading from the machine to the pulley(s) in the headroom is M_{SR1car} and rope leading from pulley(s) in the headroom to the car is M_{SR2car} ($M_{SR2car} = 0$ if car at upmost landing);

M_{SRcwt} is the mass M_{SR} on counterweight side.

In the case of machine below, the rope leading from the machine to the pulley(s) in the headroom is M_{SR1cwt} and rope leading from pulley(s) in the headroom to the counterweight is M_{SR2cwt} ($M_{SR2cwt} = 0$ if counterweight at upmost landing);

M_{Trav} is the actual mass of travelling cable ($[0,25H \pm 0,5y] \cdot n_t \cdot$ travelling cable weight per unit length) in kilograms;

n_C is the number of compensating ropes/chains;

n_S is the number of suspension ropes;

n_t is the number of travelling cables;

P is the masses of the empty car in kilograms;

Q is the rated load in kilograms;

T_1, T_2 is the force exerted on rope in newtons;

r is the reeving factor;

v_{pulley} is the rotation speed of the pulley (rope speed) in metres per second;

y is on the level $0,5 \cdot H \rightarrow y = 0$ in metres;

\rightarrow is the static force;

\rightarrow is the dynamic force;

5.12 Evaluation of safety factor on suspension ropes for electric lifts

5.12.1 General

With reference to the requirements laid down in the standards calling for the use of this standard (e.g. EN 81-20:2020, 5.5.2.2), this clause describes the method of evaluation of the safety factor " S_f " for the suspension ropes. This evaluation method shall only be used for:

- Steel or cast iron traction sheaves;
- Steel wire ropes according to EN 12385-5:2002.

NOTE This method is based on sufficient life time of the ropes assuming a regular maintenance and inspection.

5.12.2 Equivalent number N_{equiv} of pulleys

5.12.2.1 General

The number of bends and the degree of severity of each bend cause deterioration of the rope. This is influenced by the type of grooves (U- or V- groove) and whether the bend is reversed or not.

The degree of severity of each bend can be equated to a number of simple bends.

A simple bend is defined by the rope travelling over a semi-circular groove where the radius of the groove is not more than 0,53 of the nominal rope diameter.

The number of simple bends corresponds to an equivalent number of pulleys N_{equiv} , which can be derived from:

$$N_{equiv} = N_{equiv(t)} + N_{equiv(p)}$$

where:

- $N_{equiv(t)}$ is the equivalent number of traction sheaves;
- $N_{equiv(p)}$ is the equivalent number of deflection pulleys.

5.12.2.2 Evaluation of $N_{equiv(t)}$

Values of $N_{equiv(t)}$ can be taken from Table 2.

Table 2 — Evaluation of equivalent number of traction sheaves $N_{equiv(t)}$

V-grooves	V-angle (γ)	35°	36°	38°	40°	42°	45°	50°
	$N_{equiv(t)}$	18,5	16	12	10	8	6,5	5
U-Undercut grooves	U-angle (β)	75°	80°	85°	90°	95°	100°	105°
	$N_{equiv(t)}$	2,5	3,0	3,8	5,0	6,7	10,0	15,2

For U-grooves without undercut: $N_{equiv(t)} = 1$.

Values for angles not in the table may be determined by linear interpolation.

5.12.2.3 Evaluation of $N_{equiv(p)}$

A bend is only considered to be a reverse bend if the distance from the rope contacts on two consecutive pulleys, which have a fixed distance between their axles, is less than 200 times the rope diameter and the bending planes are rotated through more than 120°.

$$N_{equiv(p)} = K_p \cdot (N_{ps} + 4 \cdot N_{pr})$$

where:

- N_{ps} is the number of pulleys with simple bends;
- N_{pr} is the number of pulleys with reversed bends;
- K_p is the factor of ratio between sheave and pulley diameters.

with: $K_p = \left(\frac{D_t}{D_p} \right)^4$

where:

- D_t is the diameter of the traction sheave;
- D_p is the average diameter of all pulleys, traction sheave excluded.

NOTE Examples for evaluation of equivalent number of pulleys are given in Annex E.

5.12.3 Safety factor

For a given design of rope drive the minimum value of safety factor can be selected from Figure 10 taking into account the correct ratio of D_t/d_r and the calculated N_{equiv} for the worst case section of ropes.

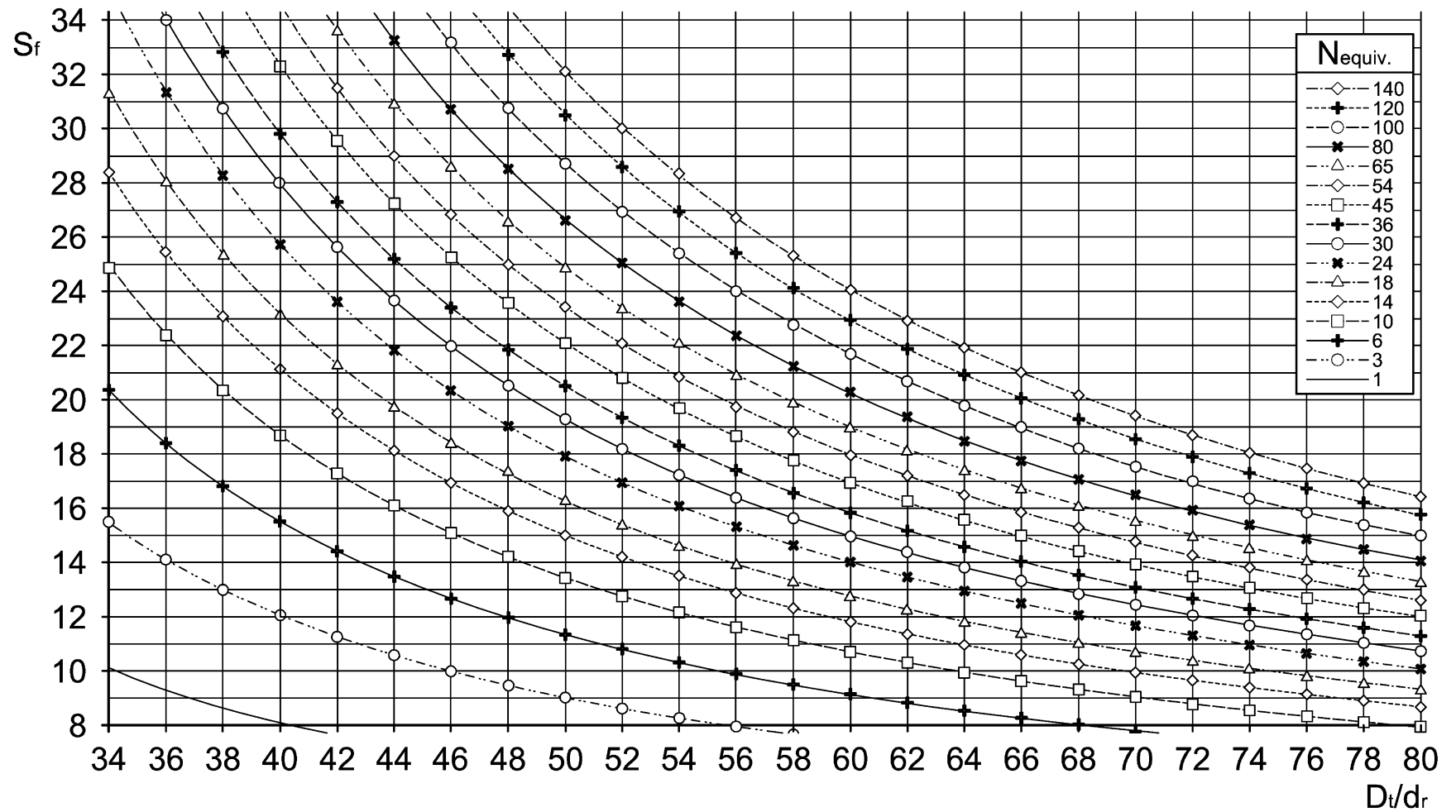

Figure 10 — Evaluation of minimum safety factor

The curves of the Figure 10 are based on the following formula:

$$S_f = 10^{\left(\frac{\log \left(\frac{695,85 \cdot 10^6 \cdot N_{equiv}}{\left(\frac{D_t}{d_r} \right)^{8,567}} \right)}{\log \left(77,09 \left(\frac{D_t}{d_r} \right)^{-2,894} \right)} \right)}$$

where:

- D_t is the diameter of traction sheave;
- d_r is the diameter of the ropes;
- N_{equiv} is the equivalent number of pulleys;
- S_f is the safety factor.

5.13 Calculations of rams, cylinders, rigid pipes and fittings

5.13.1 Calculation against over pressure

5.13.1.1 Calculation of wall thickness of rams, cylinders, rigid pipes and fittings

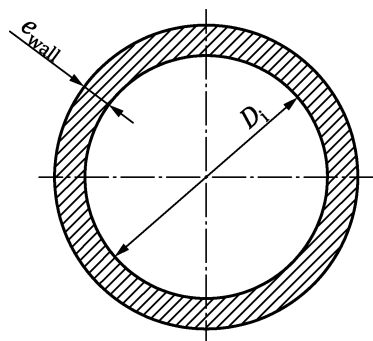

$$e_{wall} \geq \frac{2,3 \cdot 1,7 \cdot p \cdot D_i}{R_{p0,2}} + e_o$$

$e_o = 1,0$ mm for wall and base of cylinders and rigid pipes between the cylinder and the rupture valve, if any;

$e_o = 0,5$ mm for rams and other rigid pipes;

2,3 is the factor for friction losses (1,15) and pressure peaks (2);

1,7 is the safety factor referred to the proof stress.

Figure 11 — Wall thickness calculation

5.13.1.2 Calculation of the base thickness of cylinders (examples)

5.13.1.2.1 General

The examples shown do not exclude other possible constructions.

5.13.1.2.2 Flat bases with relieving groove

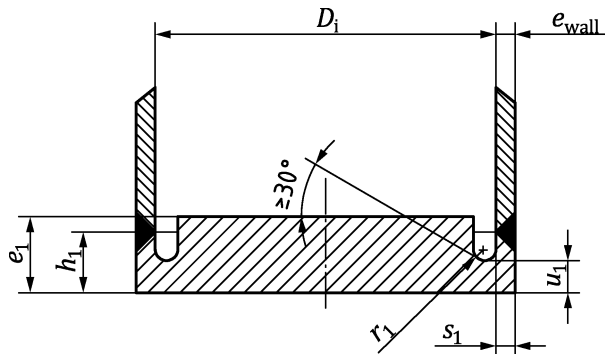

Figure 12 — Flat bases with relieving groove

Conditions for the stress relief of the welding seam:

$$r_1 \geq 0,2 \cdot e_1 \text{ and } r_1 \geq 5 \text{ mm}$$

$$u_1 \leq 1,5 \cdot s_1$$

$$h_1 \geq u_1 + r_1$$

$$e_1 \geq 0,4 \cdot D_i \sqrt{\frac{2,3 \cdot 1,7 \cdot p}{R_{P0,2}}} + e_0$$

$$u_1 \geq 1,3 \cdot \left(\frac{D_i}{2} - r_1 \right) \cdot \frac{2,3 \cdot 1,7 \cdot p}{R_{P0,2}} + e_0$$

5.13.1.2.3 Cambered based

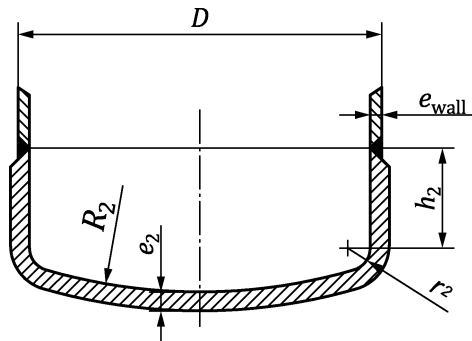

Figure 13 — Cambered based

Conditions:

$$h_2 \geq 3,0 \cdot e_2$$

$$r_2 \geq 0,15 \cdot D$$

$$R_2 = 0,8 \cdot D$$

$$e_2 \geq \frac{2,3 \cdot 1,7 \cdot p \cdot D}{R_{P0,2} \cdot 2} + e_0$$

5.13.1.2.4 Flat bases with welded flange

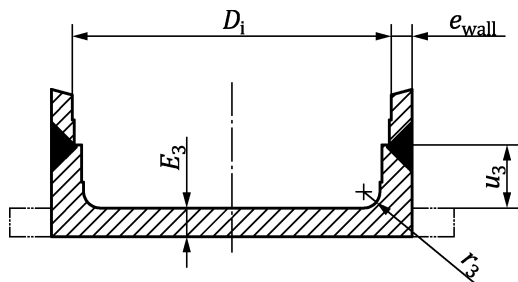

Figure 14 — Flat bases with welded flange

Conditions:

$$u_3 \geq e_3 + r_3$$

$$r_3 \geq \frac{e_{wall}}{3} \text{ and } r_3 \geq 8 \text{ mm}$$

$$e_3 \geq 0,4 \cdot D_i \sqrt{\frac{2,3 \cdot 1,7 \cdot p}{R_{P0,2}}} + e_0$$

5.13.2 Calculations of the jacks against buckling

5.13.2.1 General

The buckling calculation shall be made on the part with least buckling resistance.

5.13.2.2 Single acting jacks

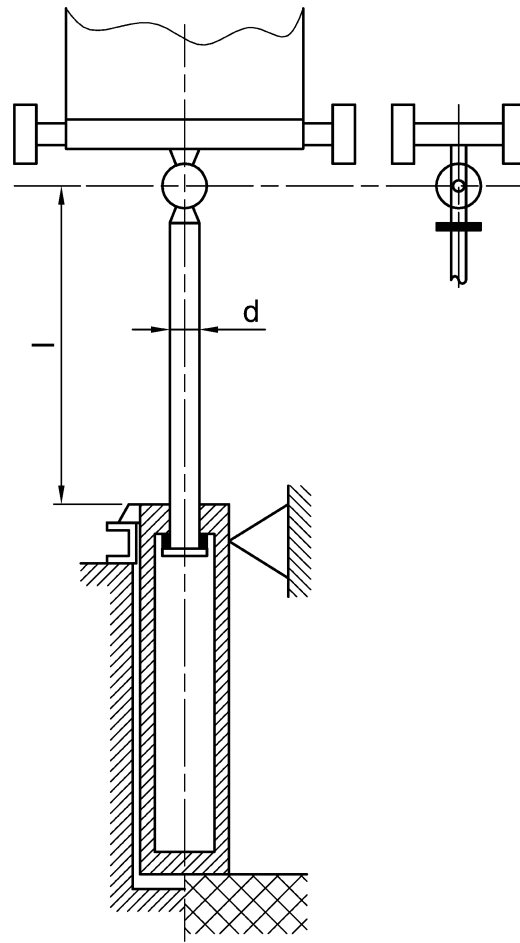

Figure 15 — Single acting jacks

For $\lambda_n \geq 100$:

$$F_s \leq \frac{\pi^2 \cdot E \cdot J_n}{2 \cdot l^2}$$

For $\lambda_n < 100$:

$$F_s \leq \frac{A_n}{2} \left[R_m - (R_m - 210) \cdot \left(\frac{\lambda_n}{100} \right)^2 \right]$$

$$F_s = 1,4 \cdot g_n \cdot [c_m \cdot (P + Q) + 0,64 \cdot P_r + P_{rh}]^{3)}$$

3) Valid for rams extending in upward direction.

5.13.2.3 Telescopic jacks without external guidance, calculation of ram

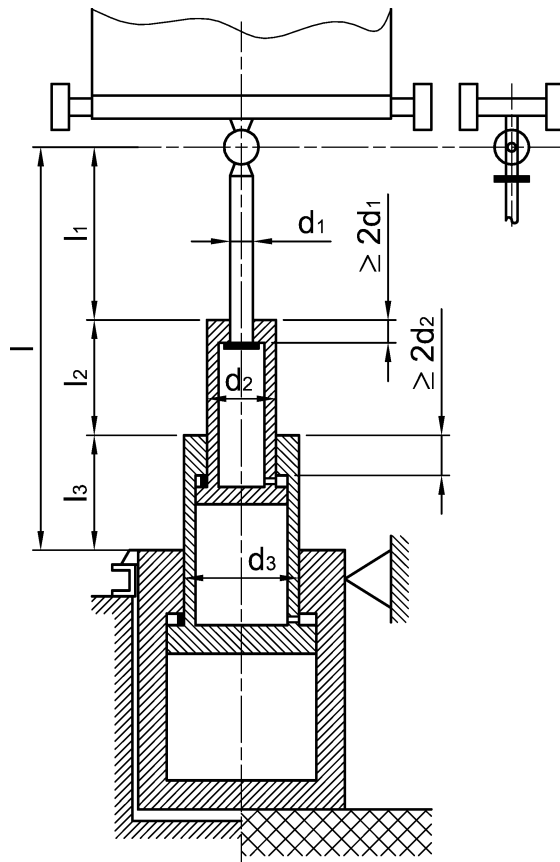

Figure 16 — Telescopic jacks without external guidance

$$l = l_1 + l_2 + l_3, \quad l_1 = l_2 = l_3$$

$$v = \sqrt{\frac{J_1}{J_2}}; \quad (J_3 \geq J_2 > J_1)$$

(assumption for simplified calculation: $J_3 = J_2$)

for 2 sections:

$$\varphi = 1,25 \cdot v - 0,2 \quad \text{for } 0,22 < v < 0,65$$

for 3 sections:

$$\varphi = 1,5 \cdot v - 0,2 \quad \text{for } 0,22 < v < 0,65$$

$$\varphi = 0,65 \cdot v + 0,35 \quad \text{for } 0,65 < v < 1$$

$$\lambda_e = \frac{l}{i_e} \quad \text{with } i_e = \frac{d_m}{4} \sqrt{\varphi \cdot \left[1 + \left(\frac{d_{mi}}{d_m} \right)^2 \right]}$$

For $\lambda_e \geq 100$:

$$F_s \leq \frac{\pi^2 \cdot E \cdot J_2}{2 \cdot l^2} \cdot \varphi$$

For $\lambda_e < 100$:

$$F_s \leq \frac{A_n}{2} \left[R_m - (R_m - 210) \cdot \left(\frac{\lambda_n}{100} \right)^2 \right]$$

$$F_s = 1,4 \cdot g_n \cdot [c_m \cdot (P + Q) + 0,64 \cdot P_r + P_m + P_{rt}]^4$$

4) Valid for rams extending in upward direction.

5.13.2.4 Telescopic jacks with external guidance

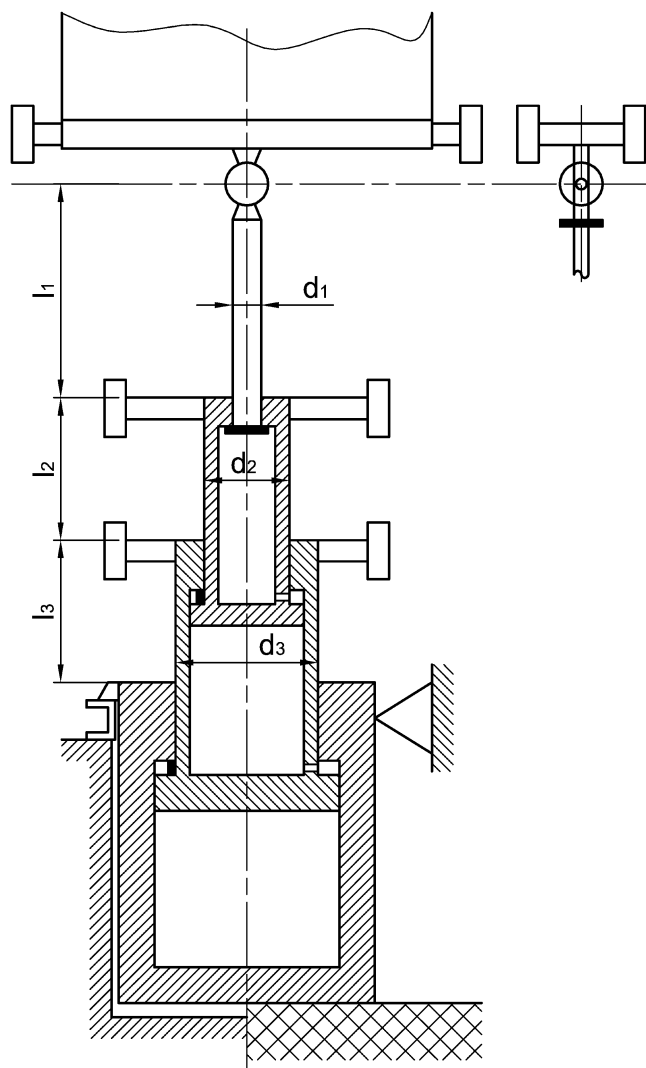

Figure 17 — Telescopic jacks with external guidance

For $\lambda_n \geq 100$:

$$F_s \leq \frac{\pi^2 \cdot E \cdot J_n}{2 \cdot l_n^2}$$

For $\lambda_n < 100$:

$$F_s \leq \frac{A_n}{2} \left[R_m - (R_m - 210) \cdot \left(\frac{\lambda_n}{100} \right)^2 \right]$$

$$F_s = 1,4 \cdot g_n \cdot [c_m \cdot (P + Q) + 0,64 \cdot P_r + P_{rh} + P_{rl}] \quad 5)$$

5) Valid for rams extending in upward direction.

Symbols

A_n	is the cross-sectional area of the material of the ram to be calculated in square millimetres ($n = 1, 2, 3$);
c_m	is the reeving ratio;
d_m	is the outside diameter of the biggest ram of a telescopic jack in millimetres;
d_{mi}	is the inner diameter of the biggest ram of a telescopic jack in millimetres;
E	is the modulus of elasticity in newtons per square millimetre (for steel: $E = 2,1 \times 10^5$ N/mm ²);
e_O	is the additional wall thickness in millimetres;
F_s	is the actual buckling force applied in newtons;
g_n	is the standard acceleration of free fall in metres per square second;
i_e	is the equivalent radius of gyration of a telescopic jack in millimetres;
i_n	is the radius of gyration of the ram to be calculated in millimetres ($n = 1, 2, 3$);
J_n	is the second moment of area of the ram to be calculated in fourth power millimetres ($n = 1, 2, 3$);
l	is the maximum length of rams subject to buckling in millimetres;
p	is the full load pressure in megapascals;
P	is the sum of the mass of the empty car and the mass of the portion of the travelling cables suspended from the car in kilograms;
P_r	is the mass of the ram to be calculated in kilograms;
P_{rh}	is the mass of the ram head equipment, if any in kilograms;
P_{rt}	is the mass of the rams acting on the ram to be calculated (in the case of telescopic jacks) in kilograms;
Q	is the rated load (mass) displayed in the car in kilograms;
R_m	is the tensile strength of material in newtons per square millimetre;
$R_{p0,2}$	is the proof stress (non-proportional elongation) in newtons per square millimetre;
$\lambda_e = \frac{l}{i_e}$	is the equivalent coefficient of slenderness of a telescopic jack;
$\lambda_n = \frac{l}{i_n}$	is the coefficient of slenderness of the ram to be calculated;
ν, φ	is the factors used to represent approximate values given by experimentally determined diagrams;
1,4	is the over pressure factor;
2	is the safety factor against buckling.

5.14 Pendulum shock tests

5.14.1 General

Pendulum shock tests shall be carried out according to the following prescriptions.

NOTE Pendulum shock test could be specified for a “family” of doors based on e.g. type and min./max. dimensions.

5.14.2 Test rig

5.14.2.1 Hard pendulum shock device

The hard pendulum shock device shall be a body according to Figure 18. This body consists of a shock ring made of steel S 235 JR, according to EN 10025 and a case made of steel E 295, according to EN 10025. The overall mass of this body will be brought up to $10 \text{ kg} \pm 0,01 \text{ kg}$ by filling with lead balls of a diameter of $3,5 \text{ mm} \pm 0,5 \text{ mm}$.

5.14.2.2 Soft pendulum shock device

The soft pendulum shock device shall be a small shot bag according to Figure 19 made of leather, which is filled with lead balls of a diameter of $3,5 \text{ mm} \pm 0,5 \text{ mm}$ up to an overall mass of $45 \text{ kg} \pm 0,5 \text{ kg}$.

5.14.2.3 Suspension of the pendulum shock device

The pendulum shock device shall be suspended by a wire rope of approximately 3 mm diameter in such a way that the horizontal distance between the outer edge of the free hanging shock device and the panel to be tested does not exceed $15 \text{ mm} \pm 10 \text{ mm}$.

The pendulum length (lower end of the hook to reference point of the shock device) shall be at least 1,5 m.

5.14.2.4 Pulling and triggering device

The suspended pendulum shock device shall be swung away from the panel by a pulling and triggering device and thus lifted to the falling height required in 5.14.3.2 and 5.14.3.3. The triggering device shall not give an additional impulse to the pendulum shock device in the moment of releasing.

The suspension wire rope shall be hooked to shock device without any torque to prevent spinning of device after triggering.

The suspension wire rope shall have no angle in swung position before triggering; consistent results should be realized by a triangle hooking keeping the shocking device centre of gravity in line with the hoisting wire at triggering position.

5.14.2.5 Test samples

5.14.2.5.1 The test samples shall be complete and shall have the intended size and fixations according to the specific application. The test samples shall be fixed to the test frame in such a way that at the fixation points, no deformations under test conditions are possible (stiff fixation).

5.14.2.5.2 The samples shall be submitted to the tests in the intended manufacturing finish (machined edges, holes, etc.).

5.14.3 Tests

5.14.3.1 The tests shall be carried out at a temperature of $23 \text{ °C} \pm 5 \text{ °C}$. The panels shall be stored directly before the tests for at least 4 hours at that temperature.

5.14.3.2 The hard pendulum shock test shall be carried out with the device according to 5.14.2.1 with a falling height and test arrangement according to Figure 18 and Figure 20.

5.14.3.3 The soft pendulum shock test shall be carried out with the device according to 5.14.2.2 with a falling height and test arrangement according to Figure 19 and Figure 20.

5.14.3.4 The pendulum shock device shall be brought to the required falling height according to the standard calling for this test (e.g. FprEN 81-20:2019, 5.3.5.3.2) and released.

If it is not possible to hit the specified striking point of the relevant part of the test sample (e.g. the panel width is smaller than 240 mm), the pendulum shock device shall hit as close as possible to the striking point (see the requirements laid down in the standards calling for the use of this standard (e.g. FprEN 81-20:2019)).

5.14.3.5 Only one test for each striking point is required with each of the devices called for in 5.14.2.1 and 5.14.2.2.

When both hard and soft pendulum shock tests shall be made, they shall be made on the same test sample and the hard pendulum test shall be performed first.

5.14.3.6 Landing doors shall be tested from the landing side. Car doors and car walls shall be tested from the car side.

5.14.4 Interpretation of the results

Checks shall be carried out after the test according to the standard calling for this test for the following:

- a) loss of integrity;
- b) permanent deformation;
- c) cracks or chips.

5.14.5 Test report

The test report shall contain at least the following information:

- a) name and address of the organization having made the tests;
- b) date of the tests;
- c) dimensions and construction of the panel;
- d) fixation of the panel;
- e) falling height of the tests;
- f) number of tests carried out;
- g) test results;
- h) signature of the person responsible for these tests.

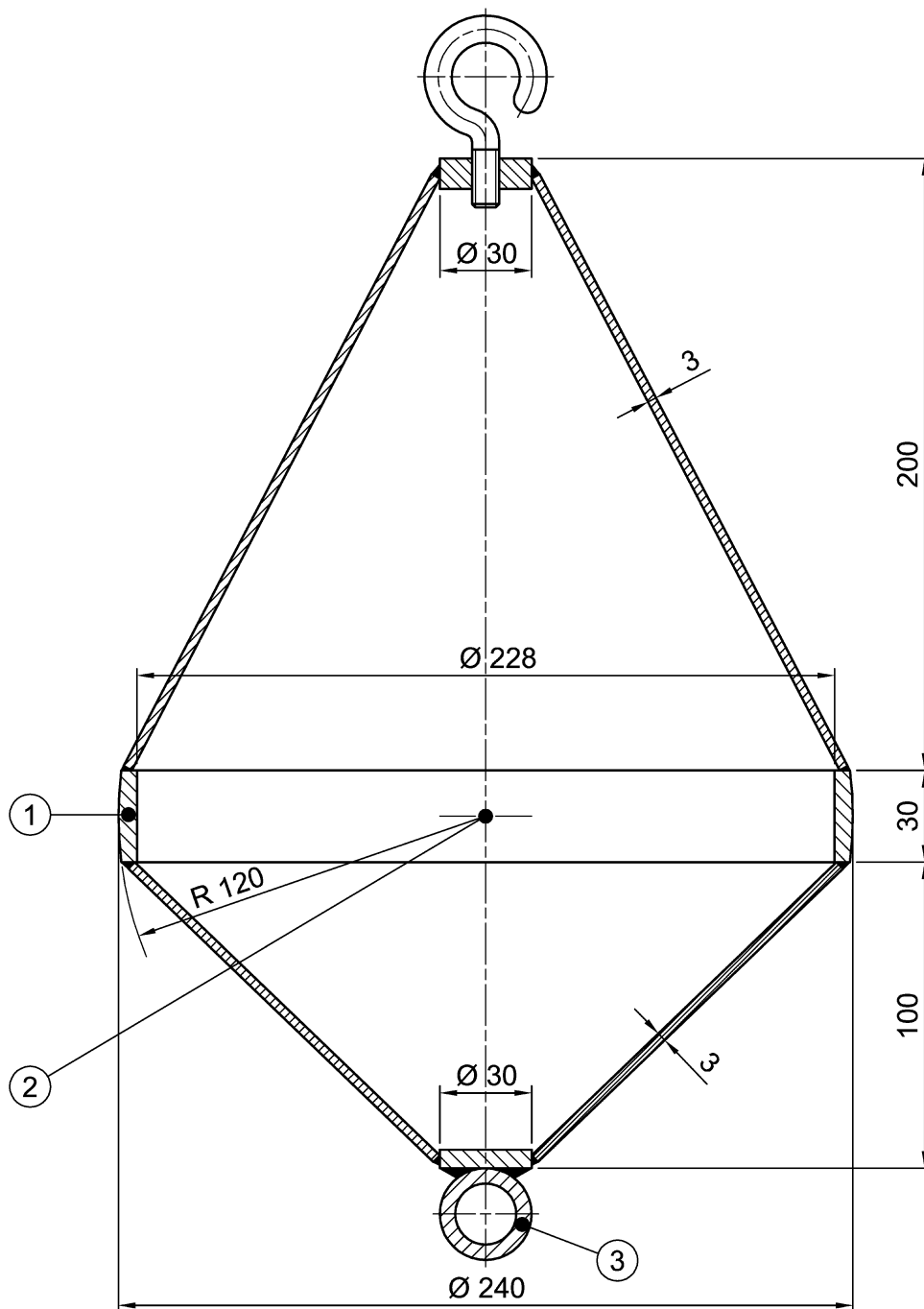

Key

- ① shocking ring
- ② reference point for measuring the falling height
- ③ triggering device attachment

Figure 18 — Hard pendulum shock device

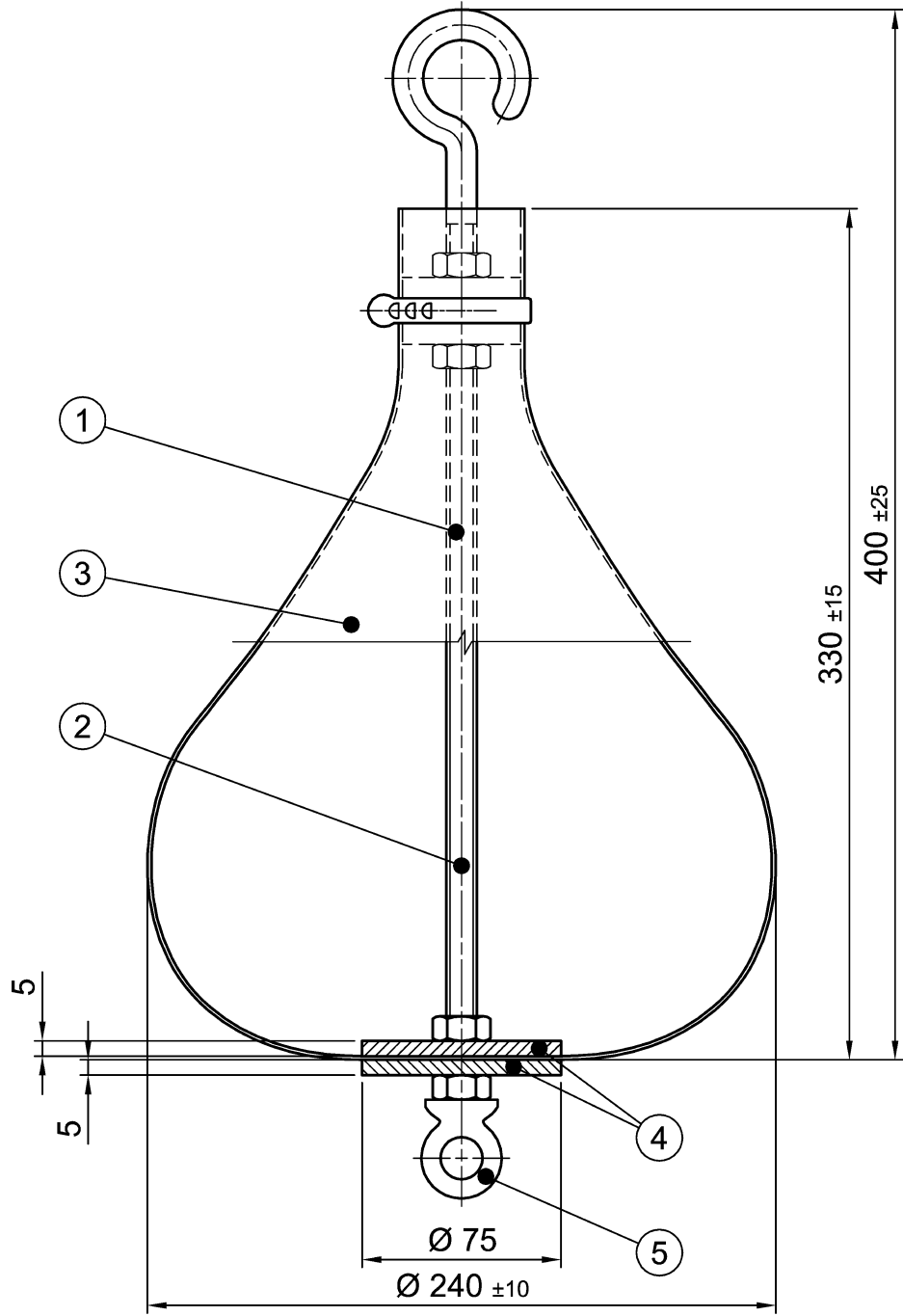

Key

- ① screwed rod
- ② reference point for measuring the falling height in the plane of the maximum diameter
- ③ leather bag
- ④ steel disk
- ⑤ triggering device attachment

Figure 19 — Soft pendulum shock device

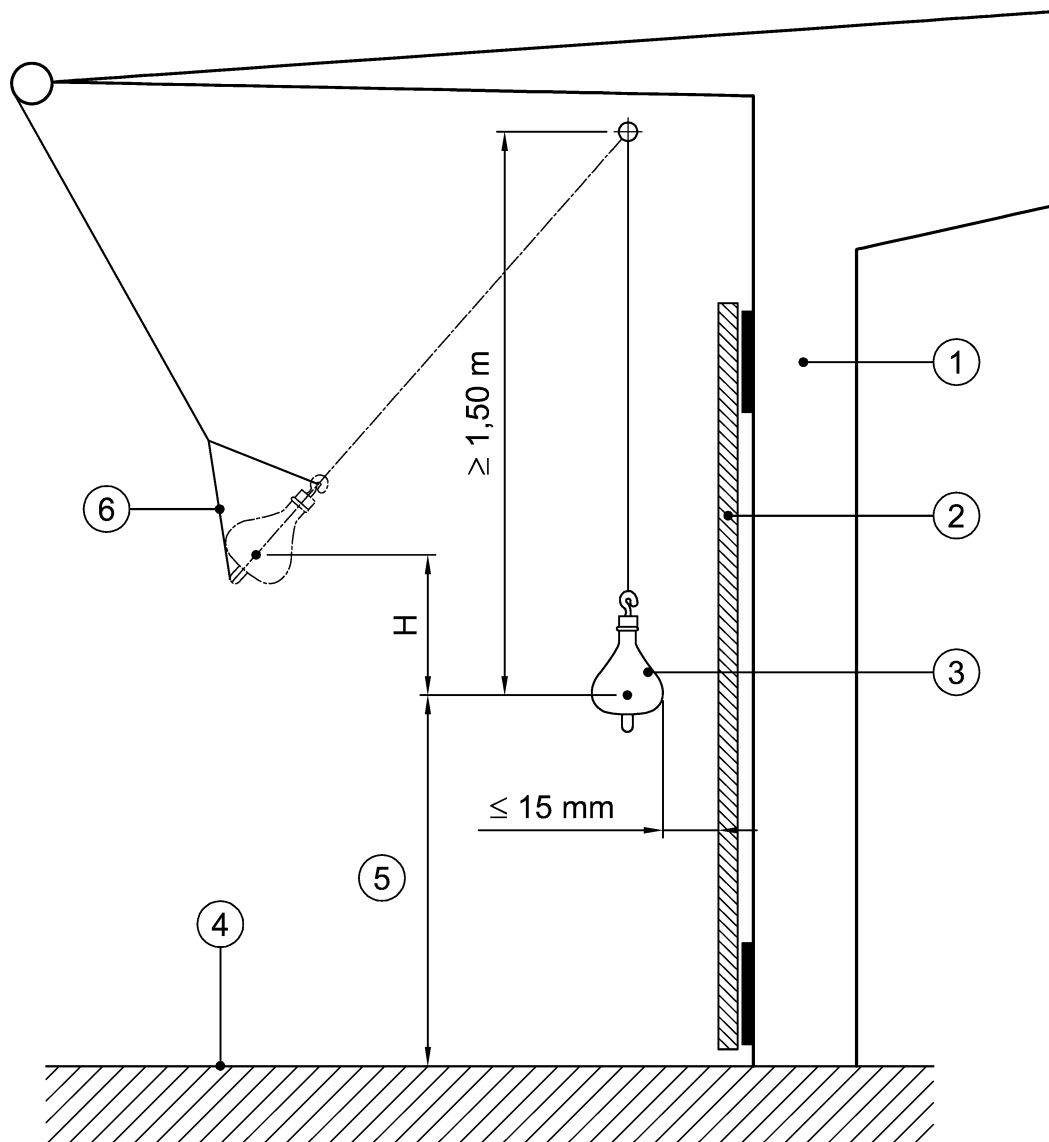

Key

- ① frame
- ② door or car wall-element to be tested
- ③ shock device
- ④ floor level with respect to the door or car wall-structure element to be tested
- ⑤ height of striking point: value for the height of striking points is given in relevant clauses
- ⑥ triangle hooking configuration as considered in 5.14.2.4
- H falling height

Figure 20 — Test rig falling height

5.15 Electronic components - Failure exclusion

Failure exclusion shall only be considered provided that components are applied within their worst case limits of characteristics, value, temperature, humidity, voltage and vibrations.

The following Table 3 describes the conditions under which certain faults can be excluded.

Table 3 — Exclusions of failures

Component	Possible failure exclusion					Conditions	Remarks
	Open circuit	Short circuit	Change to higher value	Change to lower value	Change of function		
1 Passive components							
1.1 Resistor fixed	NO	(a)	NO	(a)		(a) Only for film resistors with varnished or sealed resistance film and axial connection according to applicable IEC standards, and for wire wound resistors if they are made of a single layer winding protected by enamel or sealed.	
1.2 Resistor variable	NO	NO	NO	NO			
1.3 Resistor, non linear NTC, PTC, VDR, IDR	NO	NO	NO	NO			
1.4 Capacitor	NO	NO	NO	NO			
1.5 Inductive components - coil - choke	NO	NO		NO			
2 Semiconductors							
2.1 Diode, LED	NO	NO			NO		Change of function refers to a change in reverse current value.
2.2 Zener Diode	NO	NO		NO	NO		Change to lower value refers to change in Zener voltage. Change of function refers to change in reverse current value.
<p>In the Table: The "NO" in the cell means: failure not excluded, i.e. shall be considered; The unmarked cell means: the identified fault type is not relevant.</p>							

Component	Possible failure exclusion					Conditions	Remarks	
	Open circuit	Short circuit	Change to higher value	Change to lower value	Change of function			
<i>to be continued'</i>								
2 Semiconductors (Continued)								
2.3 Thyristor, Triac, GTO	NO	NO			NO		Change of function refers to self-triggering or latching of components.	
2.4 Optocoupler	NO	(a)			NO	(a) Can be excluded under condition that the optocoupler is according to EN 60747-5-5, and the isolation voltage is at least according to table below, EN 60664-1:2007, Table F.1.	Open circuit means open circuit in one of the two basic components (LED and photo transistor). Short circuit means short circuit between them.	
						Voltage phase-to-earth derived from rated system voltage up to and including V_{rms} and DC		Preferred series of impulse withstand voltages in volts for installation
								Category III
						50	800	
						100	1 500	
						150	2 500	
						300	4 000	
						600	6 000	
						1 000	8 000	

Component	Possible failure exclusion					Conditions	Remarks
	Open circuit	Short circuit	Change to higher value	Change to lower value	Change of function		
The "NO" in the cell means: failure not excluded, i.e. shall be considered; The unmarked cell means: the identified fault type is not relevant.							
<i>"to be continued"</i>							
2.5	Hybrid circuit	NO	NO	NO	NO	NO	
2.6	Integrated circuit	NO	NO	NO	NO	NO	Change in function to oscillation, "and" gates becoming "or" gates, etc.
3	Miscellaneous						
3.1	Connectors Terminals Plugs	NO	(a)				(a) The short circuits of connectors can be excluded if the minimum values are according to the tables (taken over from EN 60664-1:2007) with the conditions: - the pollution degree is 3; - the material group is III; - inhomogeneous field. The column "printed wiring material" of Table F.4 is not used. These are absolute minimum values which can be found on the connected unit, not pitch dimension or theoretical values. If the protection of the connector is IP 5X or better, the creepage distances can be reduced to the clearance value, e.g. 3 mm for 250 V _{rms} .
3.2	Neon bulb	NO	NO				
The "NO" in the cell means: failure not excluded, i.e. shall be considered; The unmarked cell means: the identified fault type is not relevant.							
<i>"to be continued"</i>							

Component	Possible failure exclusion					Conditions	Remarks
	Open circuit	Short circuit	Change to higher value	Change to lower value	Change of function		
3.3 Transformer	NO	(a)	(b)	(b)		(a) (b) Can be excluded under condition that transformer complies with EN 61558-1:2005, Clause 18 for double or reinforced insulation between windings and between windings and core.	Short-circuits include short-circuits of primary or secondary windings, or between primary and secondary coils. Change in value refers to change of ratio by partial short-circuit in a winding.
3.4 Fuse		(a)				(a) Can be excluded if the fuse is correctly rated, and constructed according to the applicable IEC standards.	Short circuit means short circuit of the blown fuse.
3.5 Relay	NO	(a) (b)				(a) Short-circuits between contacts, and between contacts and coil can be excluded if the relay fulfils the requirements laid down in the standards calling for the use of this standard (e.g. EN 81-20:2014, 5.10.3.2.2). (b) Welding of contacts cannot be excluded. However, if the relay is constructed to have mechanically forced interlocked contacts, and made according to EN 60947-5-1:2017, the assumptions laid down in the standards calling for the use of this standard (e.g. FprEN 81-20:2019, 5.10.3.1.2 and 5.10.3.1.3) apply.	
<p>The "NO" in the cell means: failure not excluded, i.e. shall be considered; The unmarked cell means: the identified fault type is not relevant.</p>							
<i>"to be continued"</i>							

<p>3 Miscellaneous (continued)</p>							
<p>3.6 Printed circuit board (PCB)</p>	<p>NO</p>	<p>(a)</p>				<p>(a) The short circuit can be excluded provided:</p> <ul style="list-style-type: none"> - The general specifications of PCB are in accordance with EN 62326-1; - The base material is in accordance to the specifications of EN 61249 series; - The PCB is constructed according to the above requirements and the minimum values are according to the tables (taken over from EN 60664-1:2007) with the conditions: <ul style="list-style-type: none"> - The pollution degree is 3; - The material group is III; - Inhomogeneous field. <p>The column “printed wiring material” of Table 4 is not used. That means that the creepage distances are 4 mm and the clearances 3 mm at 2000 m altitude for 250 V_{rms}</p> <p>For other voltages and higher altitude see EN 60112:2003.</p> <p>If the protection of the PCB is IP 54 or better, and the printed side(s) is (are) coated with an ageing-resistant varnish or protective layer covering all conductor paths and for the inner layers of multilayer PCB, pollution degree 2 can be used.</p> <p>NOTE: Experience has shown that solder masks are satisfactory as a protective layer.</p> <p>For multi-layer boards comprised of at least 3 prepreg or other thin sheet insulating materials, short circuit can be excluded (see EN 60950-1:2006, 2.10.6.4).</p>	

<p>The "NO" in the cell means: failure not excluded, i.e. shall be considered; The unmarked cell means: the identified fault type is not relevant.</p>							
							<i>"to be continued"</i>
4 Assembly of components on printed circuit board (PCB)	NO	(a)				(a) Short circuit can be excluded under circumstances where the short circuit of the component itself can be excluded and the component is mounted in a way that the creepage distances and clearances are not reduced below the minimum acceptable values as listed in 3.1 and 3.6 of this table, neither by the mounting technique nor by the PCB itself.	
<p>The "NO" in the cell means: failure not excluded, i.e. shall be considered; The unmarked cell means: the identified fault type is not relevant.</p>							

5.16 Design rules for programmable electronic systems (PESSRAL)

Programmable electronic systems shall comply with the minimum requirements of the safety functions common to all SIL's listed in Annex B, Tables B.1, B.2 and B.3. In addition specific measures required for SIL's 1, 2 and 3 are listed respectively in Annex B, Tables B.4, B.5 and B.6.

See also the requirements in the standard calling for the use of this standard.

NOTE The EN 61508-7:2010 clauses listed in Tables B.1 to B.6 refer to the relevant requirements in EN 61508-2:2010 and EN 61508-3:2010.

Annex A
(normative)

Model form of type examination certificate

The examination certificate shall contain the following information.

MODEL TYPE-EXAMINATION CERTIFICATE

Name of the approved body

.....

Type-examination N°

1 Type and make or trade name

2 Manufacturer's name and address

.....

3 Name and address of certificate holder

.....

4 Date of submission for type-examination

5 Certificate issued on the basis of the following requirement

.....

6 Test laboratory

7 Date and number of laboratory report

8 Date of type-examination

9 The following documents, bearing the type-examination number shown above, are annexed to this certificate

.....

10 Any additional information

.....

Place (Date)

Name and position of person signing the certificate

(Signature)

Annex B
(normative)

Programmable electronic systems in safety related applications for lifts (PESSRAL)

B.1 Common measures

Table B.1 — Common measures to avoid and detect failures - Hardware design

No	Object	Measure	EN 61508-7:2010 reference
1	Processing unit	Use of watch dog.	A.9
2	Component selection	Use of components only within their specifications	
3	I/O units and interfaces incl. Communication links	Defined safe state in the event of power failure or reset	
4	Power supply	Defined safe shut-off state in case of over-voltage or under-voltage	A.8.2
5	Variable memory ranges	Use of only solid state memories.	
6	Variable memory ranges	Read/write test of variable data memory during boot procedure	
7	Variable memory ranges	Remote access only to informative data (e.g. statistics)	
8	Invariant memory ranges	No possibility to change the program code, either automatically by the system or remote intervention	
9	Invariant memory ranges	Test of program code memory and fixed data memory during boot procedure with a method at least equivalent to sum check	A.4.2

Table B.2 — Common measures to avoid and detect failures - Software design

No	Object	Measure	EN 61508-7:2010 reference
1	Structure	Program structure (i.e. modularity, data handling, interface definition) according to the state of the art (see EN 61508-3).	B.3.4/C.2.1 C.2.9/C.2.7
2	Boot procedure	During boot procedures a safe state of the lift shall be maintained.	
3	Interrupts	Limited use of interrupts: Use of nested interrupts only if all possible sequences of interrupts are predictable.	C.2.6.5
4	Interrupts	No triggering of watchdog by interrupt procedure except in combination with other program sequence conditions.	A.9.4

No	Object	Measure	EN 61508-7:2010 reference
5	Power down	No power down procedures, such as saving of data, for safety related functions.	
6	Memory management	Stack manager in the hardware and/or software with appropriate reaction procedure.	C.2.6.4/ C.5.4
7	Program	Iteration loops shorter than system reaction time, e.g. by limiting number of loops or checking execution time.	
8	Program	Array pointer offset checks, if not included in the used programming language.	C.2.6.6
9	Program	Defined handling of exceptions (e.g. divisions by zero, overflow, variable range checking etc.) which forces the system into a defined safe state.	
10	Program	No recursive programming, except in well tried standard libraries, in approved operating systems, or in high-level language compilers. For these exceptions separate stacks for separate tasks shall be provided and controlled by a memory management unit.	C.2.6.7
11	Program	Documentation of programming library interfaces and operating systems at least as complete as the user program itself.	
12	Program	Plausibility checks on data relevant to safety functions e.g. input patterns, input ranges, and internal data.	C.2.5/C.3.1
13	Program	If any operational mode can be invoked for testing or validation purposes normal operation of the lift shall not be possible until this mode has been terminated.	EN 61508-1:2010, 7.7.2.1
14	Communication system (external and internal)	Reach a safe state with due consideration to the system reaction time in a bus communication system with safety functions in case of loss of communication or a fault in a bus participant.	A.7/A.9
15	Bus system	No reconfiguration of the CPU-bus system, except during the boot procedure. NOTE: Periodical refresh of the CPU-bus system is not considered as being reconfiguration.	C.3.13
16	I/O handling	No reconfiguration of I/O lines, except during the boot procedures. NOTE: Periodical refresh of the I/O configuration registers is not considered as being reconfiguration.	C.3.13

Table B.3 — Common measures for the design and implementation process

No	Measure	EN 61508-7:2010 reference
1	Assessment of the functional, environmental and interface aspects of the application	A.14/B.1
2	Requirement specification including the safety requirements	B.2.1
3	Reviews of all specifications	B.2.6
4	Design documentation as required in 5.6.1 and in addition: - function description including system architecture and hardware/software interaction; - software documentation including function and program flow description	C.5.9
5	Design review reports	B.3.7/B.3.8, C.5.16
6	Check of reliability using a method such as failure mode and effect analysis (FMEA)	B.6.6
7	Manufacturer's test specification, manufacturer's test reports and field test reports	B.6.1
8	Instruction documents incl. limits for intended use	B.4.1
9	Repeat and update of above mentioned measures if the product is modified	C.5.23
10	Implementation of version control of hardware and software and its compatibility.	C.5.24

B.2 Specific measures

Table B.4 — Specific measures according to SIL 1

Components and functions	Requirements	Measures	see No. in C.3	EN 61508-7:2010 reference
Structure	The structure shall be such that any single random failure is detected and the system shall go into a safe state.	One channel structure with self-test, or	M 1.1	A.3.1
		two channels or more with comparison.	M 1.3	A.2.5
Processing units	Failures in processing units, which can lead to incorrect results, shall be detected. If such a failure can lead to a dangerous situation the system shall go into a safe state.	Failure correcting hardware, or	M 2.1	A.3.4
		self-test by software, or comparator for two-channel structure, or	M 2.2 M 2.4	A.3.1 A.1.3
		reciprocal comparison by software for 2-channel structure.	M 2.5	A.3.5

Components and functions	Requirements	Measures	see No. in C.3	EN 61508-7:2010 reference
Invariant memory Ranges	Incorrect information modification, i.e. all odd bit- or 2-bit failures and some 3-bit and multi-bit failures shall be detected at the latest before the next travel of the lift.	The following measures refer only to a one-channel structure: One-bit redundancy (parity bit), or block safety with one-word redundancy.	M 3.5 M 3.1	A.5.5 A.4.3
Variable memory ranges	Global failures during addressing, writing, storing and reading as well as all odd bit and 2-bit failures and some 3-bit failures and multi-bit failures shall be detected at the latest before the next travel of the lift.	The following measures refer only to a one-channel structure: Word-saving with multi-bit redundancy, or check via test pattern against static or dynamic faults.	M 3.2 M 4.1	A.5.6 A.5.2
I/O units and interfaces incl. Communication links	Static failures and cross talk on I/O lines as well as random and systematic failures in the data flow shall be detected at the latest before the next travel of the lift.	Code safety, or test pattern.	M 5.4 M 5.5	A.6.2 A.6.1
Clock	Failures in clock generation for processing units like frequency modification or break down shall be detected at the latest before the next travel of the lift.	Watchdog with separate time base, or reciprocal monitoring.	M 6.1 M 6.2	A.9.4
Program Sequence	Wrong program sequence and inappropriate execution time of the safety related functions shall be detected at the latest before the next travel of the lift.	Combination of timing and logical monitoring of program sequence	M 7.1	A.9.4
NOTE As a consequence of the detection of a failure, a safe state of the lift shall be maintained.				

Table B.5 — Specific measures according to SIL 2

Components and functions	Requirements	Measures	see No. in C.3	EN 61508-7:2 010 reference
Structure	The structure shall be such that any single random failure is detected with due consideration to the system reaction time and that the system goes into a safe state.	One channel with self-test and monitoring, or	M 1.2	A.3.3
		two channels or more with comparison.	M 1.3	A.2.5
Processing units	Failures in processing units, which can lead to incorrect results, shall be detected with due consideration to the system reaction time. If such a failure can lead to a dangerous situation the system shall go into a safe state.	Failure correcting hardware, and	M 2.1	A.3.4
		software self-test supported by hardware for one-channel structure, or	M 2.3	A.3.3
		comparator for 2-channel structure, or	M 2.4	A.1.3
		reciprocal comparison by software for 2-channel structure.	M 2.5	A.3.5
Invariant memory ranges	Incorrect information modification, i.e. all odd bit-or 2-bit failures and some 3-bit and multi-bit failures shall be detected with due consideration to the system reaction time.	The following measures refer only to a one-channel structure:	M 3.1	A.4.3
		Block safety with one-word redundancy, or	M 3.2	A.5.6
		word saving with multi-bit redundancy.		
Variable memory ranges	Global failures during addressing, writing, storing and reading as well as all odd bit and 2-bit failures and some 3-bit failures and multi-bit failures shall be detected with due consideration to the system reaction time.	The following measures refer only to a one-channel structure:	M 3.2	A.5.6
		Word-saving with multi-bit redundancy, or	M 4.1	A.5.2
		check via test pattern against static or dynamic faults.		
I/O units and interfaces incl. communication links	Static failures and cross talk on I/O lines as well as random and systematic failures in the data flow, shall be detected with due consideration to the system reaction time.	Code safety, or	M 5.4	A.6.2
		test pattern.	M 5.5	A 6.1
Clock	Failures in clock generation for processing units like frequency modification or break down shall be detected with due consideration to the system reaction time.	Watchdog with separate time base, or	M 6.1	A 9.4
		reciprocal monitoring.	M 6.2	

Program sequence	Wrong program sequence and inappropriate execution time of the safety function shall be detected with due consideration to the system reaction time.	Combination of timing and logical monitoring of program sequence.	M 7.1	A.9.4
NOTE As a consequence of the detection of a failure, a safe state of the lift shall be maintained.				

Table B.6 — Specific measures according to SIL 3

Components and functions	Requirements	Measures	see No. in C.3	EN 61508-7:2010 reference
Structure	The structure shall be such that any single random failure is detected with due consideration to the system reaction time and that the system goes into a safe state.	2 channels or more with comparison.	M 1.3	A.2.5
Processing units	Failures in processing units, which can lead to incorrect results, shall be detected with due consideration to the system reaction time. If such a failure can lead to a dangerous situation the system shall go into a safe state.	Comparator for two channels, or reciprocal comparison by software for 2-channel structure.	M 2.4 M 2.5	A.1.3 A.3.5
Invariant memory ranges	Incorrect information modification, i.e. all 1-bit or multi-bit failures, shall be detected with due consideration to the system reaction time.	Block safety procedure with block replication, or block safety with multi-word redundancy.	M 3.3 M 3.4	A.4.5 A.4.4
Variable memory ranges	Global failures during addressing, writing, storing and reading as well as static bit failures and dynamic couplings shall be detected with due consideration to the system reaction time.	Block safety procedure with block replication, or inspection checks such as "Galpat".	M 4.2 M 4.3	A.5.7 A.5.3
I/O units and interfaces incl. communication links	Static failures and cross talk on I/O lines as well as random and systematic failures in the data flow, shall be detected with due consideration to the system reaction time.	Multi-channel parallel input and multi-channel parallel output, or output read back, or code safety, or test pattern.	M 5.1 M 5.3 M 5.2 M 5.4 M 5.5	A.6.5 A.6.3 A.6.4 A.6.2 A.6.1

Clock	Failures in clock generation for processing units like frequency modification or break down shall be detected with due consideration to the system reaction time.	Watchdog with separate time base, or reciprocal monitoring.	M 6.1 M 6.2	A.9.4
Program sequence	Wrong program sequence and inappropriate execution time of the safety function shall be detected with due consideration to the system reaction time.	Combination of timing and logical monitoring of program sequence.	M 7.1	A.9.4
NOTE As a consequence of the detection of a failure, a safe state of the lift shall be maintained.				

B.3 Descriptions of possible measures

The following Table contains descriptions of possible measures which are considered to be helpful when fulfilling the requirements laid down in the standards calling for the use of this standard (e.g. EN 81-20:2020, 5.11.2.6).

Table B.7 — Description of possible measures to failure control

Components and functions	Measure N°.	Description of measures
Structure	M 1.1	One channel structure with self-test Description: Even though the structure consists of a single channel, redundant output paths shall be provided to ensure a safe shutdown. Self tests (cyclical) are applied to the sub-units of the PESSRAL at time intervals which may be application dependent. These tests (e.g. CPU tests or memory tests) are designed to detect latent failures which are independent of the data flow. A detected failure shall cause the system to go into a safe state.
	M.1.2	One channel structure with self-test and monitoring Description: A one channel structure with self-test and monitoring consists of a separate hardware monitoring unit which, independent of the application, periodically receives test data from the system which might result from self-test procedures. In case of incorrect data, the system shall go into a safe state. At least two independent shut down paths are needed so that a shut down can be caused either by the processing unit itself or by the monitoring unit.
	M.1.3	Two channels or more with comparison Description: Two-channel safety-related design consists of two independent and feedback-free functional units. This allows the specified functions to be processed independently in each channel. For a two-channel PESSRAL exclusively designed for the function of one safety device the design of the channels may be identical in terms of hardware and software. In the case of a two-channel PESSRAL used for complex solutions (e.g.

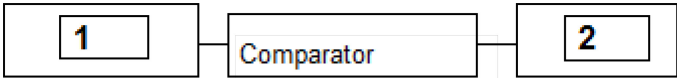
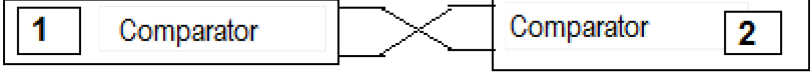
Components and functions	Measure N°.	Description of measures
		<p>combinations of several safety functions) and where the processes or conditions are not definitely verifiable, diversity for hardware and software should be considered.</p> <p>The structure includes a function which compares internal signals (e.g. bus comparison) and/or output signals which are relevant to safety functions in order to aid failure detection.</p> <p>At least two independent shut down paths are needed so that a shut down can be caused either by the channels themselves or by the comparator. The comparison itself also shall be subject to the failure recognition.</p>
Processing units	M 2.1	<p>Failure correcting hardware</p> <p>Description:</p> <p>Such units can be realized using special failure recognizing or failure correcting circuit techniques. These techniques are known for simple structures.</p>
Processing units <i>(continued)</i>	M.2.2	<p>Self-test by software</p> <p>Description:</p> <p>All the functions of the processing unit, which are used in the safety related application shall be tested cyclically.</p> <p>These tests can be combined with the test of the sub-components, e.g. memories, I/O's etc.</p>
	M.2.3	<p>Software self-test supported by hardware</p> <p>Description:</p> <p>A special hardware facility is used for the failure detection which supports the self-test functions. For example, a monitoring unit which checks the periodic output of certain bit patterns.</p>
	M 2.4	<p>Comparator for 2 channel structures</p> <p>Description:</p>  <p>Two channels with hardware comparator:</p> <p>a) The signals of both processing units are compared using a hardware unit cyclically or continuously. The comparator can be an externally tested unit or designed as a self-monitoring device or</p> <p>b) The signals of both channels are compared using a processing unit. The comparator can be an externally tested unit or designed as a self-monitoring device.</p>
	M.2.5	<p>Reciprocal comparison of 2 channels</p> <p>Description:</p>  <p>Two redundant processing units are used which exchange safety relevant data reciprocally. A comparison of the data are carried out by each unit.</p>

Components and functions	Measure N°.	Description of measures
Invariant memory Ranges (ROM, EPROM...)	M 3.1	<p>Block safety procedure with one-word-redundancy (e.g. signature formation via ROM with single word width)</p> <p>Description:</p> <p>In this test, the contents of the ROM are compressed by a certain algorithm to at least one memory word. The algorithm e.g. cyclic redundancy check (CRC), can be realized using hardware or using software.</p>
	M 3.2	<p>Word saving with multi-bit-redundancy (e.g. modified hamming code)</p> <p>Description:</p> <p>Every word of the memory is extended by several redundant bits to produce a modified hamming code with a hamming distance of at least 4. Every time a word is read, one can determine whether a corruption has taken place by checking the redundant bits. If a difference is found, the system shall go into a safe state.</p>
	M 3.3	<p>Block safety procedure with block replication</p> <p>Description:</p> <p>The address space is equipped with two memories. The first memory is operated in the normal manner. The second memory contains the same information and is accessed in parallel to the first. The outputs are compared and a failure is assumed if a difference is detected. In order to detect certain kinds of bit errors, the data shall be stored inversely in one of the two memories and inverted once again when read. In the software procedure, the contents of both memory areas are compared cyclically using a program.</p>
Invariant memory Ranges (ROM, EPROM...) (continued)	M 3.4	<p>Block safety procedure with multiword redundancy</p> <p>Description:</p> <p>This procedure calculates a signature using a CRC algorithm, but the resulting value is at least two words in size. The extended signature is stored, recalculated and compared as in a single-word case. A failure message is produced if a difference occurs.</p>
	M.3.5	<p>Word saving one bit redundancy (e.g. ROM monitoring with parity bit)</p> <p>Description:</p> <p>Every word of the memory is extended by one bit (the "parity" bit) which completes each word to an even or odd number of logical 1's. The parity of the data word is checked each time it is read. If the wrong number of 1's is found, a failure message is produced.</p> <p>The choice of even or odd parity should be made such that whichever of zero word (nothing but 0s) and the one word (nothing but 1's) is the more unfavourable in the event of failure, then that word is not a valid code. Parity can also be used to detect addressing failure, when the parity is calculated for the concatenation of the data word and its address.</p>

Components and functions	Measure N°.	Description of measures
Variable memory ranges	M 4.1	<p>Check via test pattern against static or dynamic faults, e.g. RAM test “walkpath”</p> <p>Description:</p> <p>The memory range to be tested is initialised by a uniform bit stream. The first cell is then inverted and the remaining memory area is inspected to ensure that the background is correct. After this, the first cell is re-inverted to return to its original value and the whole process is repeated for the next. A second run of the “wandering bit model” is carried out with an inverse background pre-assignment. If a difference occurs the system shall go into a safe state.</p>
	M.4.2	<p>Block safety procedures with block replication, e.g. double RAM with hardware or software comparison</p> <p>Description:</p> <p>The address space is equipped with two memories. The first memory is operated in the normal manner. The second memory contains the same information and is accessed in parallel to the first. The outputs are compared and a failure is assumed if a difference is detected. In order to detect certain kinds of bit errors, the data shall be stored inversely in one of the two memories and inverted once again when read. In the software procedure, the contents of both memory areas are compared cyclically using a program.</p>
	M.4.3	<p>Inspection to check for static and dynamic failures e.g. “GALPAT”</p> <p>Description:</p> <p>a) RAM test “galpat”: An inverse element is written into the standard pre assigned memory and then all the remaining cells are inspected to ensure that their contents are correct. After every reading access to one of the remaining cells, the inversely described cell is also inspected and read in addition to this. This process is repeated for every cell. A second run is carried out with an inverse pre-assignment. A failure is assumed if there is a difference; or</p> <p>b) Transparent “galpat” test: At the beginning of the test, a “signature” is formed using software or also hardware regarding the content of the memory range to be tested and this is stored in the register; this corresponds to the pre-assignment of the memory in the galpat test. The contents are now written into the test cell in an inverted way and inspect the contents of the remaining cells.</p> <p>The contents of the test cell are also read after every reading access to one of these cells. Since the contents of the remaining cells is indeed unknown, their</p>
Variable memory ranges (continued)	M.4.3 (continued)	<p>contents are not inspected individually, but by forming a signature once again. After this first run for the first cell, a second run for this cell takes place with contents which have been inverted several times - therefore contents which are real again. Thus, the original contents of the memory are re-established. All the other memory cells are tested in the same manner. A failure is assumed if there is a difference.</p>

Components and functions	Measure N°.	Description of measures
I / O units and interfaces	M 5.1	<p>Multi-channel parallel input</p> <p>Description: This is a data flow dependent comparison of independent inputs complying with a defined tolerance area (time value).</p>
	M.5.2	<p>Output read back (monitored output)</p> <p>Description: This is a data flow dependent comparison of outputs with independent inputs complying with a defined tolerance area (time, value). The failure cannot always be related to the defective output.</p>
	M.5.3	<p>Multi-channel parallel output</p> <p>Description: This is a data flow dependent output redundancy. Failure recognition takes place directly via the technical process or via external comparators.</p>
	M.5.4	<p>Code safety</p> <p>Description: This procedure protects the input and output information with regard to coincident failures and systematic failures. It provides data flow dependent failure recognition of the input and output units with information redundancy or/and time redundancy.</p>
	M.5.5	<p>Test pattern (model)</p> <p>Description: This is a data flow independent cyclical test of input and output units carried out with the aid of defined testing pattern to compare observations with the corresponding expected values. The testing pattern information, the testing pattern reception and testing pattern evaluation shall be independent from each other. It shall be assumed that all possible input patterns are tested.</p>
Clock	M 6.1	<p>Watch dog with separate time base</p> <p>Description: Hardware timer with separate time base triggered by correct operation of the program.</p>
	M.6.2	<p>Reciprocal monitoring</p> <p>Description: Hardware timer with separate time base triggered by the correct operation of the program of the other processor</p>
Program sequence	M 7.1	<p>Combination of timing and logical monitoring of program sequence</p> <p>Description: A time based facility monitoring the program sequence is retriggered only if the sequence of the program sections is executed correctly.</p>

Annex C (informative)

Example for calculation of guide rails

C.1 General

C.1.1 The following example is used to explain the calculation of the guide rails.

C.1.2 The following symbols for the dimensions in the lift will be used with a Cartesian coordinates system for all possible geometrical cases:

C	is the car centre;
D_x	is the car dimension in X -direction, car depth;
D_y	is the car dimension in Y -direction, car width;
δ_{str-x}	is the deflection of the building structure in the x -axis in millimetres;
δ_{str-y}	is the deflection of the building structure in the y -axis in millimetres;
h	is the distance between car guide shoes;
l	is the distance between brackets;
P	are the masses of the empty car and components supported by the car, i.e. part of travelling cable, compensating ropes/chains (if any), etc. in kilograms;
Q	is the rated load in kilograms;
S	is the car suspension;
x_c, y_c	is the position of the car centre (C) in relation to the guide rail cross coordinates;
x_i, y_i	is the position of the car door, $i = 1, 2, 3$ or 4 ;
x_p, y_p	is the position of the car mass (P) in relation to the guide rail cross coordinates;
x_Q, y_Q	is the position of the rated load (Q) in relation to the guide rail cross coordinates
x_s, y_s	is the position of the suspension (S) in relation to the guide rail cross coordinates;
$1, 2, 3, 4$	is the centre of the car door $1, 2, 3$ or 4 ;
—→	is the direction of loading.

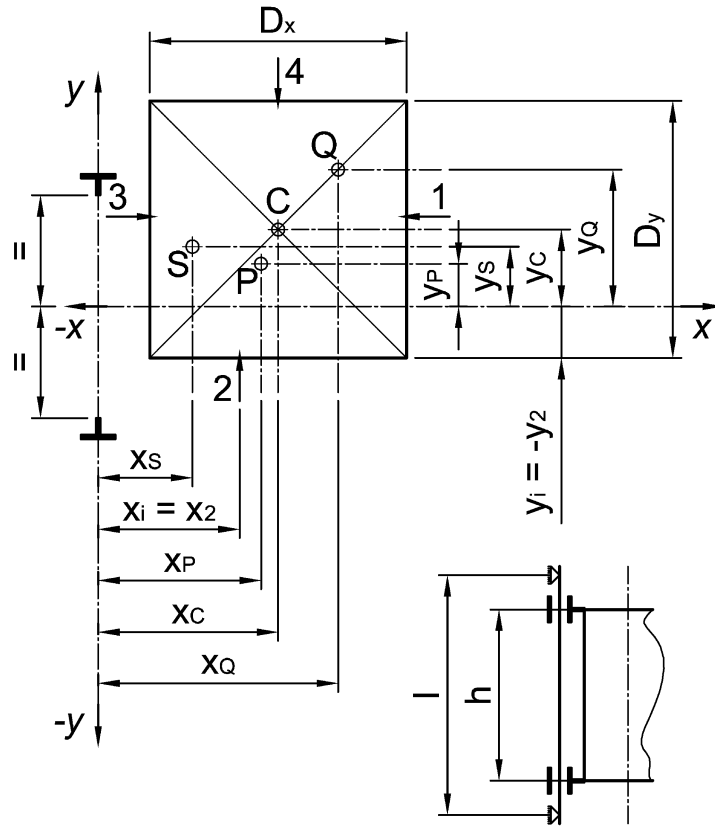

Figure C.1 — Load distribution in lift car - General case

C.1.3 The following symbols are used in the formula, see C.2 and Figure C.1:

- A is the cross sectional area of a guide rail in square millimetres;
- c is the width of the connecting part of the foot to the blade in millimetres;
- δ_{perm} is the maximum permissible deflection in millimetres;
- δ_x is the deflection in the X -axis in millimetres;
- δ_y is the deflection in the Y -axis in millimetres;
- δ_{str-x} is the deflection of the building structure in the x -axis in millimetres;
- δ_{str-y} is the deflection of the building structure in the y -axis in millimetres;
- E is the modulus of elasticity in newtons per square millimetre;
- F_p is the push through forces of all brackets at one guide rail (due to normal settling of the building or shrinkage of concrete) in newtons;
- F_s is the vertical force acting on the car sill due to loading and unloading, in newtons;
- F_v is the vertical force on a guide rail of the car, counterweight or balancing weight in newtons;
- F_x is the supporting force in the X -axis in newtons;
- F_y is the supporting force in the Y -axis in newtons;
- g_n is the standard acceleration of free fall in metres per square second;
- I_x is the second moment of area in the X -axis in fourth power millimetres;

- I_y is the second moment of area in the Y-axis in fourth power millimetres;
 k_1 is the impact factor for the type of safety gear used;
 k_2 is the impact factor for the running condition;
 k_3 is the impact factor for auxiliary parts and other operational scenarios;
 M_{aux} is the force in a guide rail due to auxiliary equipment in newtons;
 M_g is the mass of one line of guide rails in kilograms;
 M_m is the bending moment in newtons millimetres;
 M_x is the bending moment in the x-axis, in newtons millimetres;
 M_y is the bending moment in the y-axis, in newtons millimetres;
 n is the number of guide rails;
 σ is the combined stress in newtons per square millimetre;
 σ_k is the buckling stress in newtons per square millimetre;
 σ_m is the bending stress in newtons per square millimetre;
 σ_F is the local flange bending stress in newtons per square millimetre.
 σ_{perm} is the permissible stress in newtons per square millimetre;
 σ_x is the bending stress in the x-axis in newtons per square millimetre;
 σ_y is the bending stress in the y-axis in newtons per square millimetre;
 W_x is the modulus of cross sectional area in the x-axis in cubic millimetres;
 W_y is the modulus of cross sectional area in the y-axis in cubic millimetres;
 ω is the omega value.

C.2 General configuration for lifts with safety gear

C.2.1 Safety gear operation

C.2.1.1 Bending stress

- a) Bending stress relative to the y-axis of the guide rail due to guiding force:

$$F_x = \frac{k_1 \cdot g_n \cdot (Q \cdot x_Q + P \cdot x_P)}{n \cdot h} \quad M_y = \frac{3 \cdot F_x \cdot l}{16}, \quad \sigma_y = \frac{M_y}{W_y}$$

- b) Bending stress relative to the x-axis of the guide rail due to guiding force:

$$F_y = \frac{k_1 \cdot g_n \cdot (Q \cdot y_Q + P \cdot y_P)}{\frac{n}{2} \cdot h}, \quad M_x = \frac{3 \cdot F_y \cdot l}{16}, \quad \sigma_x = \frac{M_x}{W_x}$$

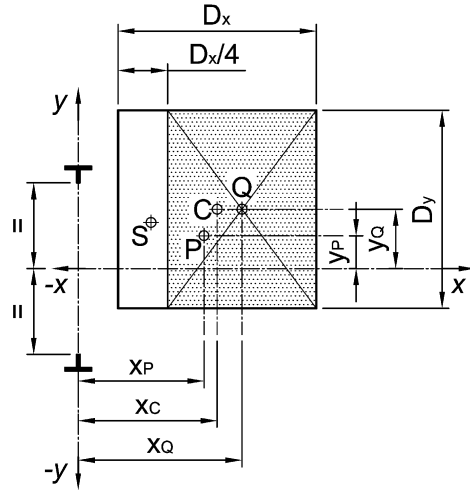

$$x_Q = x_C + D_x/8$$

$$y_Q = y_C$$

Figure C.2 — Safety gear operation - Load distribution in lift car - Case 1 relative to x-axis

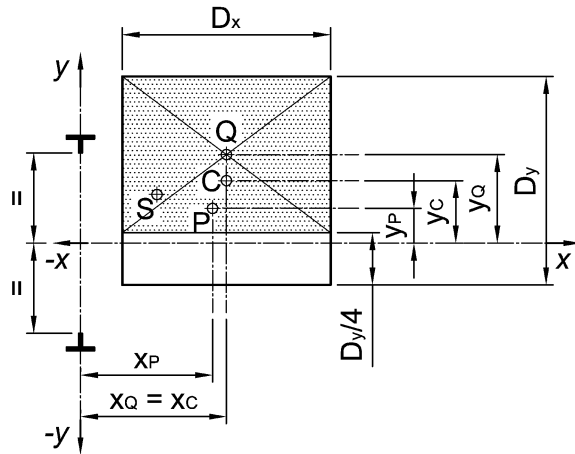

$$x_Q = x_C$$

$$y_Q = y_C + D_y/8$$

Figure C.3 — Safety gear operation - Load distribution in lift car - Case 2 relative to y-axis

C.2.1.2 Buckling

$$F_v = \frac{k_1 \cdot g_n \cdot (P + Q)}{n} + M_g \cdot g_n + F_p,$$

$$\sigma_k = \frac{(F_v + k_3 \cdot M_{aux}) \cdot \omega}{A}$$

C.2.1.3 Combined stress⁶⁾

$$\sigma = \sigma_m = \sigma_x + \sigma_y \leq \sigma_{perm},$$

$$\sigma = \sigma_m + \frac{F_v + k_3 \cdot M_{aux}}{A} \leq \sigma_{perm}$$

$$\sigma = \sigma_k + 0,9 \cdot \sigma_m \leq \sigma_{perm}$$

6) These figures apply to both load distribution cases 1 and 2, see C.2.1.1. If $\sigma_{perm} < \sigma_m$, the figures for 5.10.2.2 may be used in the interest of minimum guide rail dimensions.

C.2.1.4 Flange bending⁷⁾

$$\sigma_F = \frac{1,85 \cdot F_x}{c^2} \leq \sigma_{perm} \quad \text{or} \quad \sigma_F = \frac{6 \cdot F_x \cdot (h_l - b - f)}{c^2 \cdot (l + 2 \cdot (h_l - f))} \leq \sigma_{perm}$$

C.2.1.5 Deflections⁸⁾

$$\delta_x = 0,7 \frac{F_x \cdot l^3}{48 \cdot E \cdot I_y} + \delta_{str-x} \leq \delta_{perm} \quad \delta_y = 0,7 \frac{F_y \cdot l^3}{48 \cdot E \cdot I_x} + \delta_{str-y} \leq \delta_{perm}$$

C.2.2 Normal operation, running

C.2.2.1 Bending stress

a) Bending stress relative to the y-axis of the guide rail due to guiding force:

$$F_x = \frac{k_2 \cdot g_n \cdot [Q \cdot (x_Q - x_S) + P \cdot (x_P - x_S)]}{n \cdot h}, \quad M_y = \frac{3 \cdot F_x \cdot l}{16}, \quad \sigma_y = \frac{M_y}{W_y}$$

b) Bending stress relative to the x-axis of the guide rail due to guiding force:

$$F_y = \frac{k_2 \cdot g_n \cdot [Q \cdot (y_Q - y_S) + P \cdot (y_P - y_S)]}{\frac{n}{2} \cdot h}, \quad M_x = \frac{3 \cdot F_y \cdot l}{16}, \quad \sigma_x = \frac{M_x}{W_x}$$

Load distribution:

Case 1 relative to the x-axis (see C.2.1.1).

Case 2 relative to the y-axis (see C.2.1.1).

C.2.2.2 Buckling

$$F_v = M_g \cdot g_n + F_p \quad \sigma_v = \frac{F_v + k_3 \cdot M_{aux}}{A}$$

C.2.2.3 Combined stress⁹⁾

$$\sigma_m = \sigma_x + \sigma_y \leq \sigma_{perm} \quad , \quad \sigma = \sigma_m + \frac{F_v + k_3 \cdot M_{aux}}{A} \leq \sigma_{perm}$$

C.2.2.4 Flange bending¹⁰⁾

$$\sigma_F = \frac{1,85 \cdot F_x}{c^2} \leq \sigma_{perm} \quad \text{or} \quad \sigma_F = \frac{6 \cdot F_x \cdot (h_l - b - f)}{c^2 \cdot (l + 2 \cdot (h_l - f))} \leq \sigma_{perm}$$

7) These figures apply to both load distribution cases C.2.1.1.

8) These figures apply to both load distribution cases C.2.1.1.

9) These figures apply to both load distribution cases C.2.2.1. If $\sigma_{perm} < \sigma_m$, the figures for 5.10.2.2 may be used in the interest of minimum guide rail dimensions.

10) These figures apply to both load distribution cases C.2.1.1.

C.2.2.5 Deflection¹¹⁾

$$\delta_x = 0,7 \frac{F_x \cdot l^3}{48 \cdot E \cdot I_y} + \delta_{str-x} \leq \delta_{perm}$$

$$\delta_y = 0,7 \cdot \frac{F_y \cdot l^3}{48 \cdot E \cdot I_x} + \delta_{str-y} \leq \delta_{perm}$$

C.2.3 Normal operation, loading

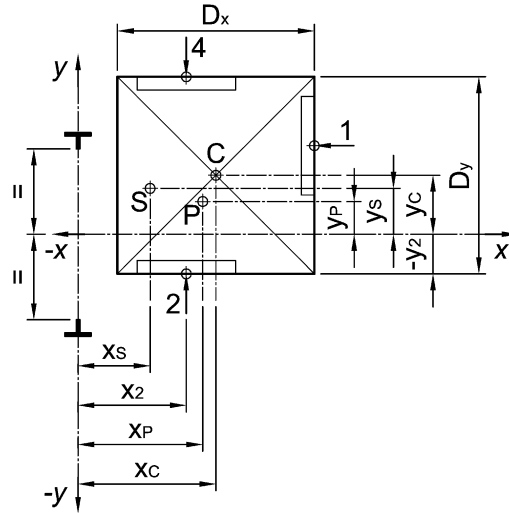

Figure C.4 — Normal operation - Loading distribution

C.2.3.1 Bending stress

a) Bending stress relative to the y-axis of the guide rail due to guiding force:

$$F_x = \frac{g_n \cdot P \cdot (x_P - x_S) + F_s \cdot (x_i - x_S)}{n \cdot h}, \quad M_y = \frac{3 \cdot F_x \cdot l}{16}, \quad \sigma_y = \frac{M_y}{W_y}$$

b) Bending stress relative to the x-axis of the guide rail due to guiding force:

$$F_y = \frac{g_n \cdot P \cdot (y_P - y_S) + F_s \cdot (y_i - y_S)}{\frac{n}{2} \cdot h}, \quad M_x = \frac{3 \cdot F_y \cdot l}{16}, \quad \sigma_x = \frac{M_x}{W_x}$$

C.2.3.2 Buckling

$$F_v = M_g \cdot g_n + F_p \quad \sigma_k = \frac{F_v + k_3 \cdot M_{aux}}{A}$$

C.2.3.3 Combined stress¹²⁾

$$\sigma = \sigma_m = \sigma_x + \sigma_y \leq \sigma_{perm}, \quad \sigma = \sigma_m + \frac{F_v + k_3 \cdot M_{aux}}{A} \leq \sigma_{perm}$$

11) These figures apply to both load distribution cases C.2.1.1.

12) If $\sigma_{perm} < \sigma_m$, the figures for 5.10.2.2 may be used in the interest of minimum guide rail dimensions.

C.2.3.4 Flange bending

$$\sigma_F = \frac{1,85 \cdot F_x}{c^2} \leq \sigma_{perm} \quad \text{or} \quad \sigma_F = \frac{6 \cdot F_x \cdot (h_l - b - f)}{c^2 \cdot (l + 2 \cdot (h_l - f))} \leq \sigma_{perm}$$

C.2.3.5 Deflections

$$\delta_x = 0,7 \frac{F_x \cdot l^3}{48 \cdot E \cdot I_y} + \delta_{str-x} \leq \delta_{perm}, \quad \delta_y = 0,7 \frac{F_y \cdot l^3}{48 \cdot E \cdot I_x} + \delta_{str-y} \leq \delta_{perm}$$

Annex D (informative)

Calculation of traction – Example

For the example according to Figure D.1 the following formulas apply.

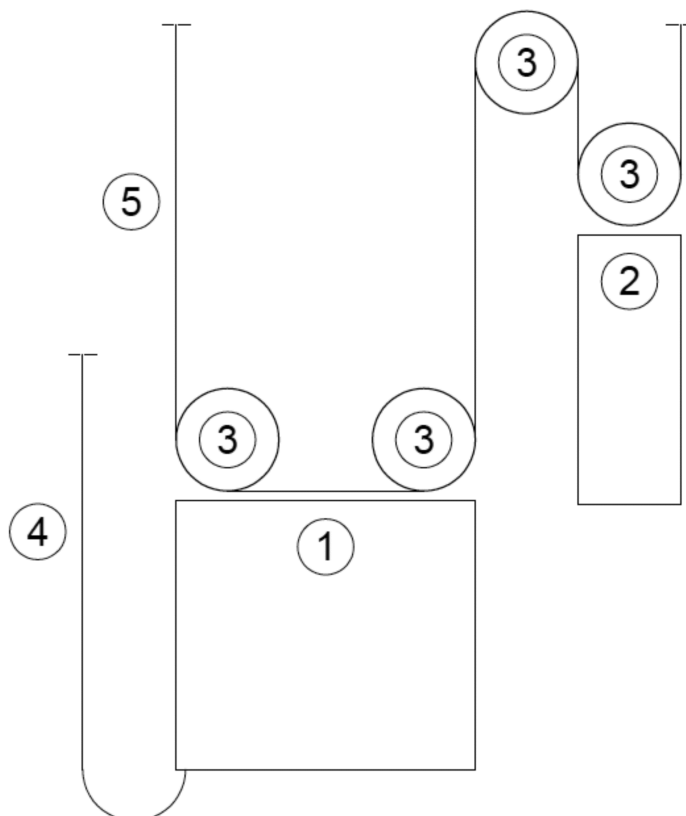

Key

- ① car
- ② counterweight
- ③ pulley
- ④ travelling cable
- ⑤ suspension means

Figure D.1 — Example 2:1, no compensation means

Car loading condition

Car loaded with 125 % rated load at lowest landing, no friction considered.

$$— T_1 = \frac{(P + 1,25 \cdot Q)}{2} \cdot g_n + M_{SRcar} \cdot g_n$$

$$— T_2 = \frac{M_{cwt}}{2} \cdot g_n$$

Emergency braking condition

Minimum friction due to pulleys and guiding force assumed

a) Car loaded with rated load at lowest landing

$$- T_1 = \frac{(P + Q)}{2} \cdot (g_n + a) + M_{SRcar} (g_n + 2 \cdot a) + \frac{m_{Pcar} \cdot 2 \cdot a}{2} - \frac{FR_{car}}{2}$$

$$- T_2 = \frac{M_{cwt}}{2} \cdot (g_n - a) - \frac{m_{Pcwt} \cdot l \cdot a}{2} + \frac{FR_{cwt}}{2}$$

b) Empty car at highest landing

$$- T_1 = \frac{M_{cwt}}{2} \cdot (g_n + a) + M_{SRcwt} (g_n + 2 \cdot a) + \frac{m_{Pcwt} \cdot l \cdot a}{2} - \frac{FR_{cwt}}{2}$$

$$- T_2 = \frac{(P + M_{Trav})}{2} \cdot (g_n - a) - \frac{m_{Pcar} \cdot 2 \cdot a}{2} + \frac{FR_{car}}{2}$$

Counterweight stalled condition

Empty car at highest position, no friction considered.

$$- T_1 = \frac{(P + M_{Trav})}{2} \cdot g_n$$

$$- T_2 = M_{SRcwt} \cdot g_n$$

Annex E (informative)

Equivalent number of pulleys N_{equiv} - Examples

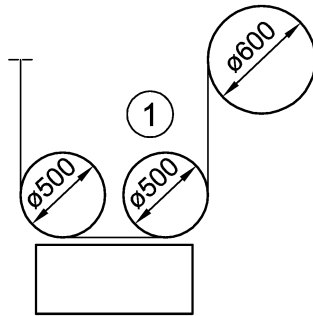

Key

①: Car side

$$\gamma = 40^\circ$$

$$N_{equiv(t)} = 10 \text{ (according to Table 2)}$$

$$K_p = (600 / 500)^4 = 2,07$$

$$N_{equiv(p)} = 2,07 \cdot (2 + 0) = 4,14$$

$$N_{equiv} = 10 + 4,14 = 14,14$$

NOTE No reversed bend because of moving pulley.

Figure E.1 — 2 to 1 roping - V grooves

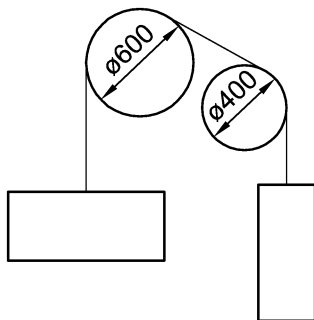

$$\beta = 90^\circ$$

$$N_{equiv(t)} = 5 \text{ (according to Table 2)}$$

$$K_p = (600 / 400)^4 = 5,06$$

$$N_{equiv(p)} = 5,06 \cdot (1 + 0) = 5,06$$

$$N_{equiv} = 5 + 5,06 = 10,06$$

Figure E.2 — 1 to 1 roping - Undercut U grooves

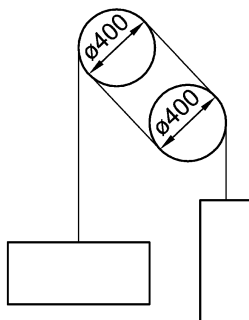

$$N_{equiv(t)} = 1 + 1$$

$$K_p = 1$$

$$N_{equiv(p)} = 1 \cdot (1 + 1) = 2$$

$$N_{equiv} = 2 + 2 = 4$$

NOTE The rope passes traction sheave and secondary sheave 2 times

Figure E.3 — 1 to 1 roping (double wrap) - U grooves

Annex ZA (informative)

Relationship between this European Standard and the essential requirements of Directive 2014/33/EU aimed to be covered

This European Standard has been prepared under a Commission's standardization request "M/549 C(2016) 5884 final" to provide one voluntary means of conforming to essential requirements of Directive 2014/33/EU of the European Parliament and of the Council of 26 February 2014 on the harmonization of the laws of the Member States relating to lifts and safety components for lifts (recast).

Once this standard is cited in the Official Journal of the European Union under that Directive, compliance with the normative clauses of this standard, given in Table ZA.1 and Table ZA.2, confers within the limits of the scope of this standard, a presumption of conformity with the corresponding essential requirements of that Directive and associated EFTA regulations.

Table ZA.1 — Correspondence between this European Standard and Annex I of Directive 2014/33/EU

Essential Requirements of Directive	Clause(s)/subclause(s) of this EN	Remarks/Notes
1.1	See Table ZA.2	Referring to the application of Directive 2006/42/EC
1.4.2	5.4	Type examination of overspeed governors
1.4.4	5.11, 5.12	Evaluation of traction and safety factor on suspension ropes for electric lifts
1.6.4	5.6, 5.15, 5.16	Type examination of safety circuits containing electronic components and/or programmable electronic systems (PESSRAL), Electronic components - Failure exclusion,
2.3	5.2, 5.14	Type examination of landing and car door locking devices, Design rules for programmable electronic systems (PESSRAL)
3.2	5.3, 5.7, 5.8, 5.9, 5.10	Type examination of safety gear, ascending car overspeed protection means, unintended car movement protection means, rupture valve/one-way restrictor. Guide rails calculation
3.3	5.5	Type examination of buffers

Table ZA.2 — Correspondence between this European Standard and Annex I of Directive 2006/42/EC applicable to lifts as referred to by the Directive 2014/33/EU Annex I, 1.1

Essential Requirements of Directive	Clause(s)/subclause(s) of this EN	Remarks/Notes
1.1.2	5.1	General requirements
1.2	5.6, 5.15, 5.16	Control Systems
1.3.2	5.10, 5.13, 5.14	Risk of break-up during operation
4.1.2.2	5.10	Guide rails calculation
4.1.2.3	5.10, 5.13, 5.14	Mechanical strength

WARNING 1 — Presumption of conformity stays valid only as long as a reference to this European Standard is maintained in the list published in the Official Journal of the European Union. Users of this standard should consult frequently the latest list published in the Official Journal of the European Union.

WARNING 2 — Other Union legislation may be applicable to the product(s) falling within the scope of this standard.

Bibliography

- [1] CEN/TS 81-11, *Safety rules for the construction and installation of lifts - Basics and interpretations - Part 11: Interpretations related to EN 81 family of standards*
- [2] EN 60747-5-5, *Semiconductor devices - Discrete devices - Part 5-5: Optoelectronic devices - Photocouplers*
- [3] EN 60950-1:2006, *Information technology equipment - Safety - Part 1: General requirements*
- [4] EN 61249, *(all parts), Materials for printed boards and other interconnecting structures (IEC 61249)*
- [5] EN 61558-1:2005, *Safety of power transformers, power supplies, reactors and similar products - Part 1: General requirements and tests*
- [6] EN 62326-1, *Printed boards - Part 1: Generic specification*